

User Manual

Tektronix

Phaser[®] 560
Color Laser Printer

Copyright © Tektronix, Inc. Printed in the United States of America. Unpublished rights reserved under the copyright laws of the United States. Contents of this publication may not be reproduced in any form without permission of Tektronix, Inc.

This instrument, in whole or in part, may be protected by one or more U.S. or foreign patents or patent applications. Information provided upon request from Tektronix, Inc., P.O. Box 1000, Wilsonville, Oregon 97070-1000.

Tektronix[®], Phaser[®], and Made For Each Other[®] are registered trademarks of Tektronix, Inc. TekColor[™], PhaserLink[™], PhaserPrint[™], PhaserSym[™], PhaserTools[™], and PhaserShare[™] are trademarks of Tektronix, Inc. TekColor CareSM is a service mark of Tektronix, Inc.

Adobe[®], Acrobat[®], Acrobat[®] Reader, Illustrator[®], PageMaker[®], Photoshop[®], and PostScript[®] are registered trademarks and Brilliant Screens[™] and IntelliSelect[™] are trademarks of Adobe Systems Incorporated or its subsidiaries which may be registered in certain jurisdictions.

Apple[®], LaserWriter[®], LocalTalk[®], Macintosh[®], and TrueType2[®] are registered trademarks and Mac[™] OS is a trademark of Apple Computer, Incorporated.

Ethernet[®] is a registered trademark of Xerox Corporation.

FTP[®] Software is a registered trademark of FTP Software, Incorporated.

ITC Avant Garde Gothic[®], ITC Bookman[®], ITC Zapf Chancery[®], and ITC Zapf Dingbats[®] are registered trademarks of International Typeface Corporation.

Times[™], Helvetica[™] and Palatino[™] are trademarks of Linotype-Hell AG and/or its subsidiaries.

MS-DOS[®] and Windows[®] are registered trademarks of Microsoft Corporation.

Novell[®] and NetWare[®] are registered trademarks of Novell, Incorporated.

SPARC[®] is a registered trademark of SPARC International, Incorporated. SPARCstation[™] is a trademark of SPARC International, Incorporated, licensed exclusively to Sun Microsystems, Incorporated.

Sun[®], Sun Microsystems[®], and Sun Microsystems Computer Corporation[®] are registered trademarks of Sun Microsystems, Incorporated.

UNIX[®] is a registered trademark in the US and other countries, licensed exclusively through X/Open Company Limited.

Other marks are trademarks or registered trademarks of the companies with which they are associated.

PCL[®] is a registered trademark of Hewlett-Packard Corporation.

PANTONE[®] Colors generated by the Phaser 560 Color Printer are four- and/or three-color process simulations and may not match PANTONE-identified solid color standards. Use current PANTONE Color Reference Manuals for accurate colors.

PANTONE Color simulations are only obtainable on this product when driven by qualified Pantone-licensed software packages. Contact Pantone, Inc. for a current list of qualified licensees.

All trademarks noted herein are either the property of Tektronix, Inc., Pantone, Inc., or their respective companies.

© Pantone, Inc., 1988.

Phaser® 560 Color Laser Printer Warranty

Tektronix warrants that the Phaser 560 Color Laser Printer will be free from defects in materials and workmanship for a period of one (1) year from the date of shipment and that Customer-Replaceable Components (CRCs)* in this product will be free from defects in materials and workmanship for a period of ninety (90) days from the date of shipment or six months where longer periods are required by law. If the product or its CRCs prove defective during their respective warranty periods, Tektronix, at its option, will either repair the defective product or CRC without charge for parts and labor, or provide a replacement in exchange for the defective product or CRC.

The 90-day warranty applies only to CRCs returned to the designated Tektronix depot or the Tektronix authorized representative from which the CRC was originally purchased. For CRCs returned to other locations, Customer will be assessed an applicable service charge. The preceding limitation shall not apply within the European Economic Area, where CRCs may be returned for warranty service to the nearest designated service depot regardless of the place of purchase.

In order to obtain service under the 90-day CRC warranty, Customer must provide the applicable office of Tektronix or its authorized representative with notice of the defect before the expiration of the warranty period and make suitable arrangements for the performance of service. Customer shall be responsible for packaging and shipping the defective CRC to the service center designated by Tektronix or its representative, with shipping charges prepaid. Tektronix or its representative shall pay for the return of the CRC to Customer. Customer shall be responsible for paying any associated taxes or duties.

In order to obtain service under the one-year on-site product warranty, Customer must notify Tektronix or its authorized representative of the defect before the expiration of the warranty period and make suitable arrangements for the performance of service. Tektronix or its authorized representative will provide such service at the Customer's site, if required, without charge during the warranty period, if the service is performed within the United States or outside the United States if the product is located in a normal on-site service area. Outside the U.S., a description of the normal on-site service area can be obtained from the Local Tektronix Subsidiary or Authorized Tektronix Distributor.

This warranty shall not apply to any defect, failure or damage caused by improper use or improper or inadequate maintenance and care. Tektronix shall not be obligated to furnish service under this warranty:

- a) to repair damage resulting from attempts by personnel other than Tektronix representatives to install, repair or service the product or CRC;
- b) to repair damage resulting from improper use or connection to incompatible equipment;
- c) to repair any damage or malfunction caused by the use of non-Tektronix supplies or consumables;
- d) to repair a product or CRC that has been modified or integrated with other products when the effect of such modification or integration increases the time or difficulty of servicing the product or CRC;
- e) to repair damage or malfunction resulting from failure to perform user maintenance and cleaning at the frequency and as prescribed in the user manual; or
- f) to repair this product after the limit of its duty cycle of 100,000 monochrome pages per month and 25,000 color pages per month has been reached; all service thereafter shall be billed on a time and material basis.
- g) to repair or replace CRCs that have been used beyond their stated capacities.

THE ABOVE WARRANTIES ARE GIVEN BY TEKTRONIX WITH RESPECT TO THIS PRODUCT AND ITS CUSTOMER-REPLACEABLE COMPONENTS IN LIEU OF ANY OTHER WARRANTIES, EXPRESS OR IMPLIED. TEKTRONIX AND ITS VENDORS DISCLAIM ANY IMPLIED WARRANTIES OF MERCHANTABILITY OR FITNESS FOR A PARTICULAR PURPOSE. TEKTRONIX' RESPONSIBILITY TO REPAIR OR REPLACE DEFECTIVE PRODUCTS AND CUSTOMER-REPLACEABLE COMPONENTS IS THE SOLE AND EXCLUSIVE REMEDY PROVIDED TO THE CUSTOMER FOR BREACH OF THIS WARRANTY. TEKTRONIX AND ITS VENDORS WILL NOT BE LIABLE FOR ANY INDIRECT, SPECIAL, INCIDENTAL, OR CONSEQUENTIAL DAMAGES IRRESPECTIVE OF WHETHER TEKTRONIX OR THE VENDOR HAS ADVANCE NOTICE OF THE POSSIBILITY OF SUCH DAMAGES.

* Customer-Replaceable Components in this product are specifically: fuser, fuser roll, imaging unit, transfer kit (transfer roller and waste bin) and toner cartridges.

Users safety summary

Terms in manual: CAUTION Conditions that can result in damage to the product.
WARNING Conditions that can result in personal injury or loss of life.

Power source: Do not apply more than 250 volts RMS between the supply conductors or between either supply conductor or ground. Use only the specified power cord and connector. Refer to a qualified service technician for changes to the cord or connector.

Operation of product: Avoid electric shock by contacting a qualified service technician to replace fuses inside the product. Do not operate without the covers and panels properly installed. Do not operate in an atmosphere of explosive gases.

Safety instructions: Read all installation instructions carefully before you plug the product into a power source.

Terms on product: CAUTION A personal injury hazard exists that may not be apparent. For example, a panel may cover the hazardous area. Also applies to a hazard to property including the product itself.
DANGER A personal injury hazard exists in the area where you see the sign.

Care of product: Disconnect the power plug by pulling the plug, not the cord. Disconnect the power plug if the power cord or plug is frayed or otherwise damaged, if you spill anything into the case, if product is exposed to any excess moisture, if product is dropped or damaged, if you suspect that the product needs servicing or repair, and whenever you clean the product.

Ground the product: Plug the three-wire power cord (with grounding prong) into grounded AC outlets only. If necessary, contact a licensed electrician to install a properly grounded outlet.

Symbols as marked on product:

DANGER high voltage:



Protective ground (earth) terminal:



Use caution. Refer to the manual(s) for information:



WARNING: If the product loses the ground connection, usage of knobs and controls (and other conductive parts) can cause an electrical shock. Electrical product may be hazardous if misused.

This product is certified under IEC 825 as a Class 1 Laser Product:



WARNING: For your protection, do not defeat any interlocks.

CAUTION: This product utilizes a laser. Use of control or adjustments or performance of procedures other than those specified herein may result in hazardous radiation exposure. Do not open covers and do not repair yourself. Refer servicing to qualified personnel.

When you operate this equipment, the socket outlet should be near the equipment and be easily accessible.

<p>DANGER: Invisible laser radiation when open and interlock defeated. AVOID DIRECT EXPOSURE TO BEAM.</p>	<p>CAUTION: Invisible laser radiation when open and interlocks defeated. AVOID DIRECT EXPOSURE TO BEAM.</p>	<p>VORSICHT: Unsichtbare Laserstrahlung, wenn Abdeckung geöffnet und Sicherheitsverriegelung überbrückt. NICH DEM STRAHL AUSSETZEN.</p>	<p>ATTENTION: Rayonnement laser invisible dangereux en cas d'ouverture et lorsque la sécurité est neutralisée. EXPOSITION DANGEREUSE AU FAISCEAU.</p>	 Class 3B	
<p>PELIGRO: Cuando se abre y se invalida el bloqueo, se producen radiaciones invisibles de láser. EVITESE LA EXPOSICIÓN DIRECTA A TALES RAYOS.</p>	<p>VARNING: Osynlig laserstrålning när denna del är öppnad och spärrar är urkopplade. STRÅLEN ÄR FARLIG.</p>	<p>VARO! Näkymätön näkymätön avtaissa ja suojalukitus ohitettaessa olet alttiina lasersäteilylle. ÄLÄ KATSO SÄTEESÄEN.</p>	<p>VARNING: Osynlig laserstrålning när denna del är öppnad och spärrar är urkopplade. BETRAKTA EJ STRÅLEN.</p>	<p>ADVARSEL: Usynlig laserstrålning ved åbning når sikkerhedsafbrydere er ude af funktion. UNDGÅ UD ÆTTELSE FOR STRÅLING.</p>	<p>ADVARSEL: Usynlig laserstrålning når deksel åbnes og sikkerhedsglas brytes. UNNGÅ EKSPONERING FOR STRÅLEN.</p>

PJQT4521ZA

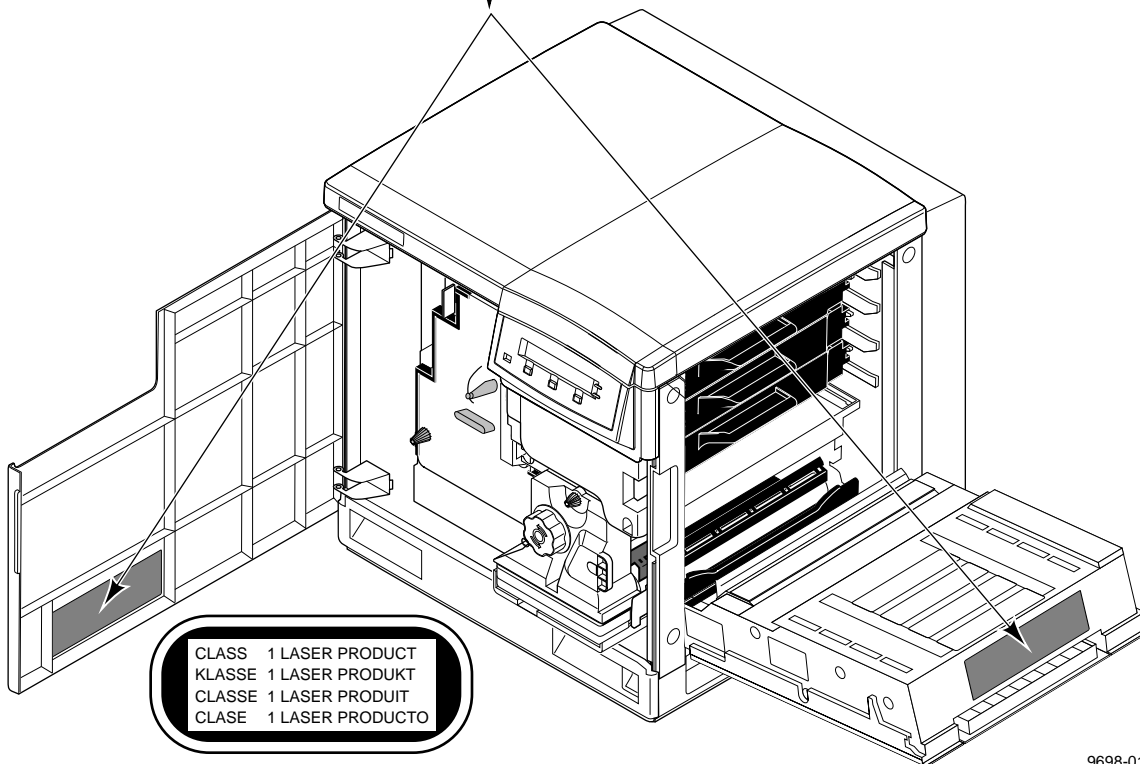

FOR USERS IN NORWAY

VARNING! OM APPARATEN ANVANDS PÅ ANNAT SÄTT ÄN I DENNA BRUKSANVISNING SPECIFICERATS, KAN ANVÄNDAREN UTSÄTTAS FÖR OSYNLIG LASERSTRÅLING, SOM ÖVERSKRIDER GRÄNSEN FÖR LASERKLASS 1.

Tekniska specifikationer för lasern

Uteffekt: 5 mW max.
Våglängd: 780 nm
Effektgrad för stråling: Kontinuerlig

KLASS 1 LASER APPARAT

Apparaten skall anslutas till jordat uttag när den ansluts till ett Nätverk.

FOR USERS IN JAPAN

This equipment is in the 2nd Class category (information equipment to be used in a residential area or an adjacent area thereto) and conforms to the standards set by the Voluntary Control Council For Interference by Information Technology Equipment aimed at preventing radio interference in such residential area.

When used near a radio or TV receiver, it may become the cause of radio interference. Read the instructions for correct handling.

Contents

1 Introduction

2 Getting Set Up

At a glance 2-1

Setting up the printer 2-2

 What you get with your printer 2-2

 Registering your printer 2-5

 Removing the packing material 2-6

 Installing the optional Lower Tray Assembly 2-7

 Installing the toner cartridges 2-8

 Preparing the imaging unit 2-10

 Setting up the output tray 2-11

 Insert the Quick Reference Guide 2-11

 Adding paper or transparencies 2-12

Connecting the printer 2-18

 Printer ports 2-18

 Turning on the printer 2-20

Selecting a language for the front panel 2-22

Making a demonstration print 2-23

Setting the Energy Star Timeout 2-24

3 Installing Printer Software

PC/Windows software 3-1

 Installing printer software for Windows 95 3-2

 Installing printer software for Windows NT 4.0 3-4

 Installing printer software for Windows NT 3.51 3-6

 Installing printer software for Windows 3.1 3-8

 Setting up the printer on a network (Windows NT 3.5 and 3.51) 3-12

 Setting up the printer on a network (Windows NT 4.0) 3-14

Macintosh software 3-16

 Overview for Mac™ OS platforms 3-16

Workstation software 3-22

4 Printing Basics

Printing from a PC 4-1

Using the AdobePS 4 driver with Windows 95 4-4

Using the Windows NT 4.0 PostScript driver 4-6

Using the Windows NT 3.5 and 3.51 PostScript driver 4-8

Using the Tektronix printer driver for Windows 3.1 4-9

Using the Adobe PostScript driver for Windows 3.1 4-10

Setting the timeouts 4-11

Printing from a Macintosh 4-12

Using the Phaser 560 printer driver 4-15

Using the Apple LaserWriter 8 printer driver 4-16

Using the Phaser 560 GX printer driver 4-17

Printing from a workstation 4-18

Printing from specific applications 4-20

Print features 4-20

Print-quality modes 4-23

Color corrections 4-24

Output Order 4-25

Fonts 4-26

Resident typefaces (PostScript) 4-26

Resident typefaces (PCL5) 4-28

Downloading fonts 4-28

Macintosh fonts 4-28

Printer languages: PostScript, HP-GL, PCL5 4-29

All about media 4-30

Media sizes 4-30

Margins and print area 4-31

Media types 4-32

Media trays 4-34

Using the Multi-Purpose Feeder 4-40

Loading specialty media in the Multi-Purpose Feeder 4-44

Duplex printing 4-54

5 Printing: Beyond the Basics

- Special printing features 5-2
 - Controlling color density 5-2
 - Using the Quick Collate option 5-8
 - Previewing with Check Print 5-11
 - Image Smoothing 5-14
 - Automatic tray switching 5-14
 - Getting job information 5-15
- Working with color 5-16
- Color corrections — making the best selection 5-17
 - Deciding which color correction to use 5-18
 - Color correction descriptions 5-20
 - Special considerations 5-24
- Printing and using the color sampler charts 5-25

6 Caring for Your Printer

- Overview 6-1
- User-replaceable components 6-2
 - When to replace components 6-3
 - Consumable life information 6-4
- Replacing the components 6-5
 - Toner cartridges 6-5
 - Imaging unit 6-6
 - Fuser 6-7
 - Fuser Roll 6-8
 - Transfer kit 6-9
 - Main Charge Grid 6-10
- Occasional cleaning 6-11
 - Cleaning the paper-pick and paper-feed rollers 6-12
 - Cleaning other rollers 6-16
 - Cleaning the sensor 6-16
- Repacking the printer 6-18

7 Troubleshooting

- If you need help 7-1
- Receiving email update notices 7-2
- Using the automated fax systems 7-3
- Symptoms and solutions 7-4
 - Diagnostic tools 7-4
 - Maintaining print quality 7-6
- Printing hints 7-21
 - Improving print speed 7-22
 - PostScript printing errors 7-26
 - Printed colors are not what you expected 7-29
 - Selecting page sizes in Windows applications 7-33
 - Fonts printing incorrectly from Windows 7-35
 - Sharing the printer on a network 7-36
 - Startup page prints even though it is disabled 7-37
 - Media hints and tips 7-38
- Clearing a media jam 7-39

8 Using the Front Panel

- Front panel 8-1
 - Front panel indicators 8-1
 - Front panel buttons 8-2
 - Two-line display 8-4
 - Printer information 8-5
 - Protected mode for the front panel menu 8-6
 - Front panel menu map 8-7
- Printing Help Pages 8-8
 - Enabling and disabling the Startup Page 8-10

9 Supplies, Accessories, and Expanding Your Printing System

Tektronix Printer and Tektronix supplies:

Made For Each Other® 9-1

Customizing your printer 9-1

Supplies and accessories 9-2

Interface cables and adapters 9-4

Expanding your printing system 9-5

Upgrade kits 9-5

Extended Features upgrade 9-6

Memory upgrade 9-7

PhaserShare network cards 9-8

Phaser Copystation accessory 9-9

Lower Tray Assembly 9-9

PhaserPrint for UNIX 9-10

SCSI hard disk 9-10

10 Regulatory Information and Specifications

Canadian EMC (Electromagnetic Compatibility) regulatory standards 10-1

Declaration of conformity (for 220-230 VAC equipment) 10-2

FCC Class B device (for 100-120 VAC equipment) 10-3

Material Safety Data Sheets 10-4

MSDS for Toner 10-5

Specifications 10-7

Index

Introduction

Features

The Phaser[®] 560 Color Laser Printer provides fast, high-quality color printing on plain paper and specialty media, plus the ease of operation and high performance you expect from a color laser printer. Some of its features include:

Feature	Description
High quality	Crisp 600 dots-per-inch (dpi) printing with high-definition screening produces bright colors and clean text suited for nearly any application. Optionally available, full 1200 dpi imaging provides near-photographic print quality.
High speed	<p>Fast Monochrome Mode 14 pages per minute (ppm) monochrome at 600 dpi (prints using black toner).</p> <p>Fast Color Mode Nearly 5 ppm full color printing at 600 dpi (prints using CMY toners).</p> <p>Presentation Mode Nearly 4 ppm full color, 14 ppm monochrome, at 600 x 600 dpi.</p> <p>Standard Mode Nearly 4 ppm full color, 14 ppm monochrome, at 600 dpi.</p> <p>Premium Mode * Nearly 2 ppm full color, 7 ppm monochrome, at 1200 dpi.</p>
Workgroup-efficient	High-capacity, easy-to-replace components minimize user intervention. Fast throughput and automatic tray switching make the Phaser 560 printer an excellent central resource for large or small workgroups.
Color calibration	A front panel control allows you to adjust individual color densities.

* Requires the Extended Features option.

1 Introduction

Feature	Description
Job Collation feature *	Generates multiple copies of a multiple-page job in collated order.
Check Print capability *	Allows you to preview a large print job before running the entire job.
Phaser Copystation †	This optional accessory enables your printer to be used as a color copier.
Special media	A Multi-Purpose Feeder, with up to 100 sheet-capacity, accommodates the following: <ul style="list-style-type: none">■ Paper (single- <i>and</i> double-sided)■ Tektronix Transparencies■ Tektronix Glossy Coated Paper■ Card Stock■ #10 Envelopes■ Pre-cut Labels■ Tektronix Fabric Transfer
Duplex printing	Print double-sided on laser paper — either from the paper trays or the Multi-Purpose Feeder.
Plain paper	Prints on common office papers: <ul style="list-style-type: none">■ 60-105 g/m² (16-28 lb.)■ 75-165 g/m² (20-44 lb.) Paper trays Multi-Purpose Feeder
Media sizes	<ul style="list-style-type: none">■ Letter, A4, Legal■ 89 x 254 mm to 216 x 356 mm (3.5 x 10 in. to 8.5 x 14 in.) Paper and Transparency trays Multi-Purpose Feeder
Lower Tray Assembly	The optional Lower Tray Assembly provides two additional media trays, especially useful for automatic media selection when running large print jobs.
TekColor™ Dynamic Correction	Tektronix' exclusive color-control technology makes it easy to print the colors you want. Includes the new Automatic color correction that adjusts the color quality for the best reproduction and print speed of each page in a document, depending on the elements (graphics and images) on each page.

* Requires the Extended Features option.

† Requires at least 24 Mbytes of memory.

Feature	Description
Easy to connect	Bi-directional parallel port with plug-and-play support; PhaserShare™ cards provide optional network interfaces for Ethernet (Novell NetWare, EtherTalk, and TCP/IP), Token Ring (Novell NetWare, TokenTalk, and TCP/IP), as well as LocalTalk (LocalTalk and RS-232).
PhaserLink™ software printer control and information access	<p>PhaserLink software provides a breakthrough in printer control and information access, using HTTP (HyperText Transfer Protocol, the basis for World Wide Web browsers). This software allows you to use a standard web browser for these tasks:</p> <ul style="list-style-type: none"> ■ View printer status ■ Control printer configuration ■ View consumable information ■ Link to online documentation via the World Wide Web <p>Note To use PhaserLink software, the printer must be connected to a network running TCP/IP. Refer to the <i>PhaserShare Status Software User Manual</i> for complete details.</p>
Font capacity	The Phaser 560 Color Printer has 17 resident PostScript fonts in the standard configuration, upgradable to 39 fonts with the Extended Features option. Additionally, it accepts Adobe Type 1, Type 3, and TrueType downloadable fonts as well as a variety of user-defined fonts. For additional font storage, the printer provides a SCS (Small Computer System Interface) port that allows you to attach an external hard disk.
Improved reporting on consumable usage and replacement	<ul style="list-style-type: none"> ■ Consumables Page ■ Startup Page ■ Configuration Page ■ PhaserLink software reporting ■ Front panel status messages ■ Front panel menus ■ Front panel Info button (troubleshooting and job reporting)

* Requires the Extended Features option.

Information roadmap

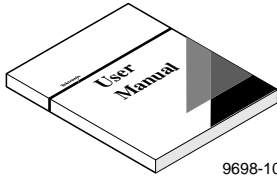

9698-105

Phaser 560 Color Laser Printer User Manual

Includes information on setting up, using, and caring for the printer:

- Hardware and software set up
- Selecting print features
- Caring for your printer (when and how to replace consumables; cleaning)
- Troubleshooting
- Upgrade and ordering information

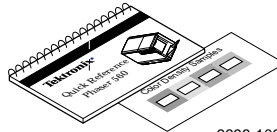

9698-106

Quick Reference Guide

Designed for handy access to the information you need at the printer:

- Supplies information
- All about media (types, sizes, and using)
- Replacing consumables
- Color calibration
- Maintaining print quality: troubleshooting and occasional cleaning
- Online access information



Consumables Instruction Sheets

Detailed, illustrated instructions included with each of the consumables.

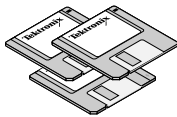

9698-107

Diskettes

Contain printer drivers, printer description files, color sampler charts, and utility files.

CD-ROM



9698-108

Contains printer drivers, printer description files, color sampler charts, and utility files, the contents of this user manual in Acrobat (PDF) format and HTML format, Adobe® Acrobat® Reader software, and supplemental information in PDF and HTML formats:

- Using the printer's downloadable utility files
- Printing HP-GL files
- Printing from workstations
- Using PANTONE Colors

For instructions on installing and using Adobe Acrobat Reader to view PDF files, refer to the *README* files on the CD-ROM.

World Wide Web



If you have access to the Internet, you can view documentation topics and answers to Frequently Asked Questions available at Tektronix' web site:

http://www.tek.com/Color_Printers/userdoc/introduction.html

PhaserShare™ manuals*

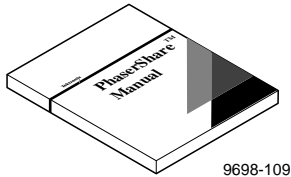

9698-109

Contain complete information on setting up and using the PhaserShare network ports.

Phaser Copystation User Manual*

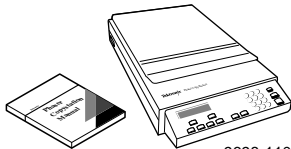

9698-110

Includes information for setting up and using the Copystation with your printer.

* Optional items.

Getting Set Up

At a glance

Installation of your printer involves these tasks:

1. **Setting up the printer**
Putting all the pieces together: unpacking the printer and accessories, installing the optional Lower Tray Assembly or the optional Phaser Copystation, loading the media tray(s), and installing the toner cartridges.
2. **Connecting power and interface cables**
3. **Selecting a language for the front panel**
4. **Installing printer software on your computer**
Refer to page 3-1 for complete instructions.

Note *To add a SCSI hard disk to your printer, see “Adding a hard disk for font storage” on the printer’s CD-ROM or the Tektronix World Wide Web site:*

`http://www.tek.com/Color_Printers/`

Setting up the printer

What you get with your printer

The printer and its accessories are shipped in a single box. If you ordered an optional Lower Tray Assembly or Phaser Copystation, each is shipped separately.

The following items are shipped with the printer:

1. *Quick-Start Installation Instructions*
2. *Phaser 560 Color Laser Printer User Manual*
3. Phaser 560 printer CD-ROM and diskettes
4. Registration card and license agreement
5. *Quick Reference Guide* and *Color Density Samples*
6. Supplies information sheet
7. Power cord
8. Parallel cable adapter
9. Optional PhaserShare software manuals and diskettes
10. Four starter toner cartridges (black, cyan, magenta, and yellow)
11. Media

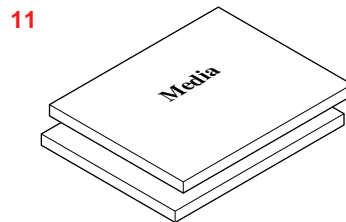
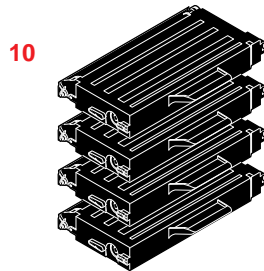
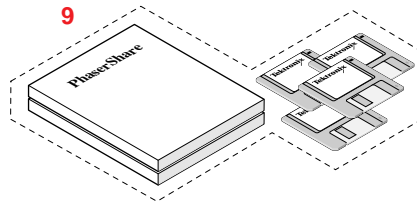
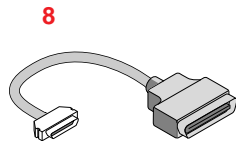
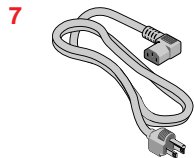
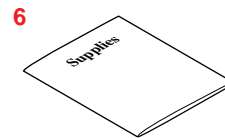
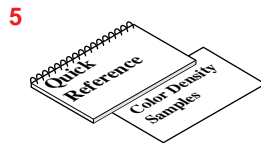
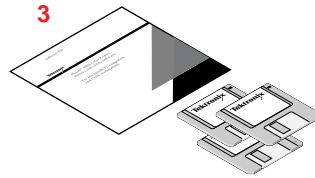
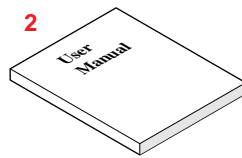

9698-02

Optional accessories

1. Lower Tray Assembly, PAPER tray and TRANSPARENCY tray
2. Phaser Copystation
3. SCSI hard disk

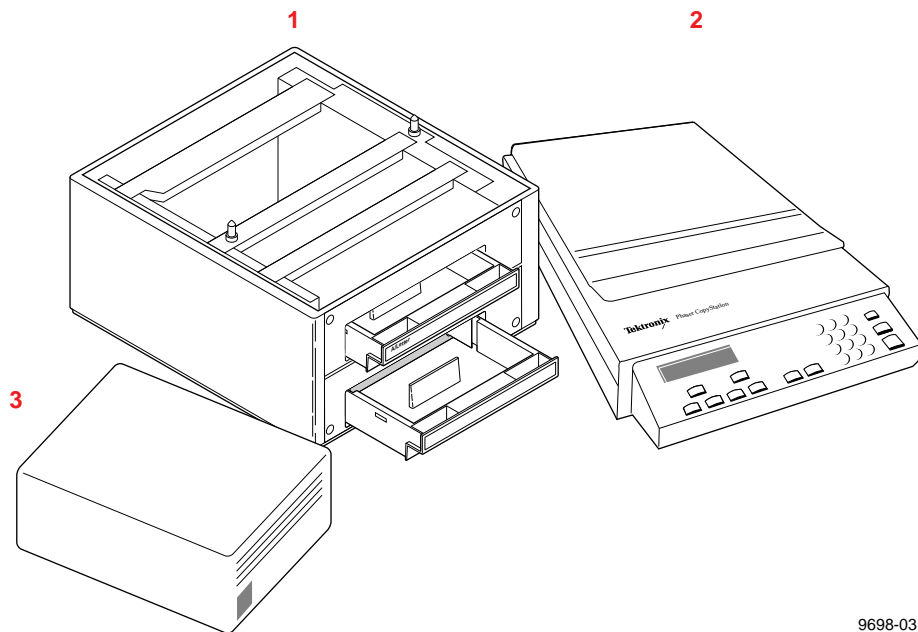

9698-03

Registering your printer

By registering your printer with Tektronix, you are validating the product warranty and ensuring that you will be sent information about upgrades, service, and accessories as it becomes available.

Register your printer using one of these methods:

In the accessories box

A customer registration card is included with the printer.

or

From the printer

At power-up, the printer automatically produces a Registration Page (if Letter-size paper is loaded and the printer's page count is 6, 7, or 8).

1. Fill out the customer registration card that is appropriate for you (U.S. or international versions).



2. Mail the registration form to Tektronix.

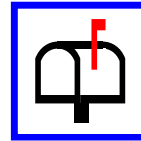

Removing the packing material

1. Remove the plastic bag from the printer.
2. Remove any adhesive tape that holds the printer's doors shut.

Note *Save all packing material in case moving or subsequent shipment is necessary.*

Installing the optional Lower Tray Assembly

An optional Lower Tray Assembly is available with the printer; it provides two additional media trays (in addition to the standard media tray and the multi-purpose feeder). Follow these steps to install the Lower Tray Assembly.

Warning *The printer weighs about 43 kg. (94 lbs.) and the Lower Tray Assembly weighs about 14 kg (31 lbs.). Observe standard precautions for lifting heavy objects.*

The printer is not permanently attached to the Lower Tray Assembly. When you move the printer, move the pieces separately; moving the printer incorrectly may damage it and may cause personal injury.

1. Place the Lower Tray Assembly on a solid, level table or cart you have selected for your printer.
2. Place the printer on top of the Lower Tray Assembly. Always keep the printer upright.
3. Make sure that the front and back alignment pins fit in the holes in the base of the printer.

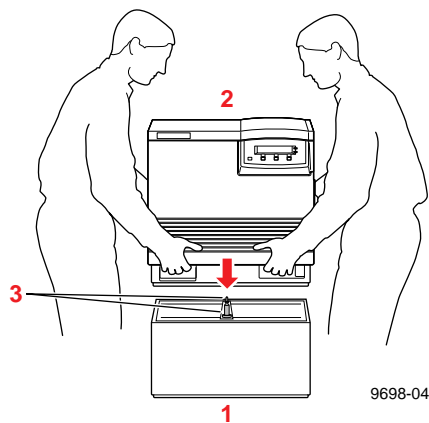

Installing the toner cartridges

Note *The toner cartridges that are shipped with the printer are starter cartridges. They are installed the same as High-Capacity cartridges; the only difference is that starter cartridges have less toner.*

1. Remove each toner cartridge from its packaging.

Note *Instructions for loading each toner cartridge are the same except for the slot into which you insert each cartridge.*

2. Remove the shipping cover from each cartridge.

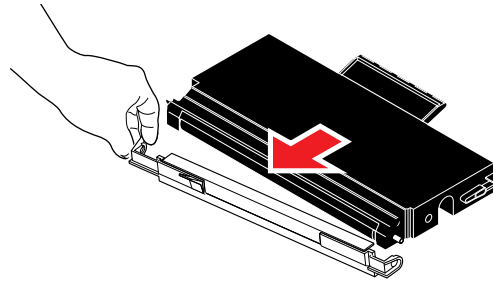

9698-05

3. Open the printer's right side door to install the toner cartridges.

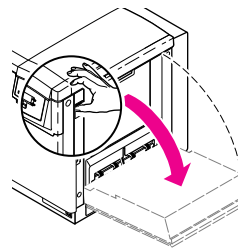

9008-91

Caution *When installing the cartridges, be careful not to leave the side door open for an extended time; other components are exposed to light and can be damaged by light exposure.*

4. Insert each toner cartridge in the slot labeled for its color.

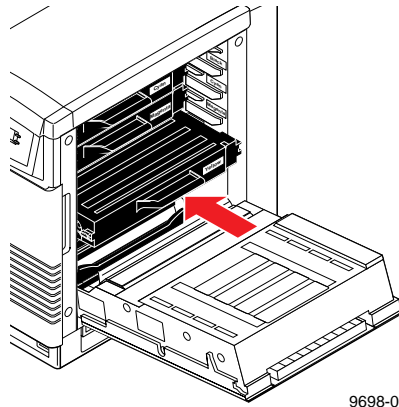

9698-06

From top to bottom, the order of the color toner cartridges is Black, Cyan, Magenta, Yellow.

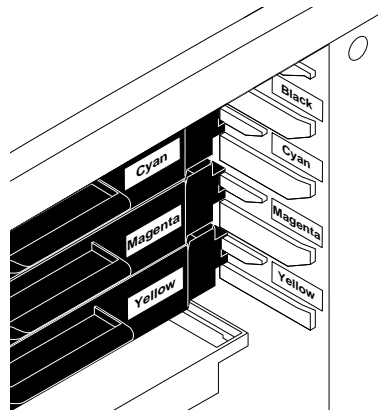

9698-07

Preparing the imaging unit

Before operating the printer, you must perform these steps to prepare the imaging unit for printing:

1. Open the printer's front door.

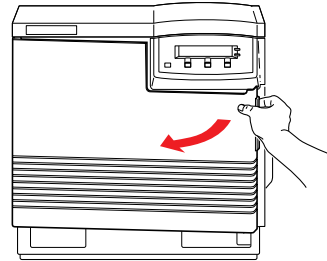

9698-08

2. Turn the upper lever 90° clockwise to align the lever's triangle with the triangle on the surface of the imaging unit.

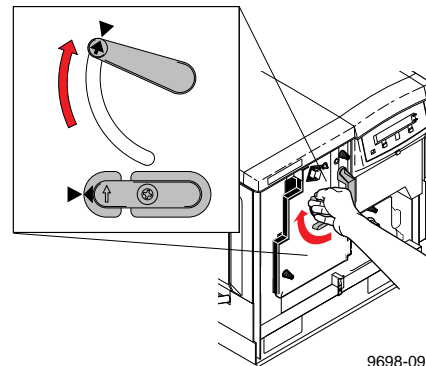

9698-09

3. Close the printer's front door.

Setting up the output tray

Remove the adhesive tape that holds the output tray against the printer; gently lower it to its operating position.

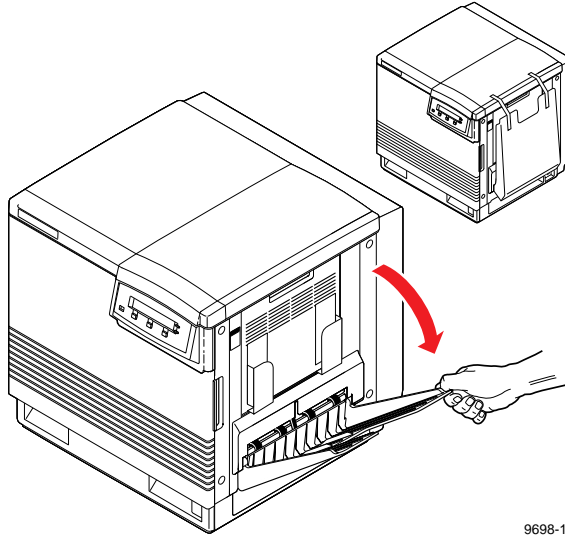

9698-10

Insert the Quick Reference Guide

Remove the *Phaser 560 Color Laser Printer Quick Reference Guide* from the accessories box and insert it into the document holder on the side of the printer.

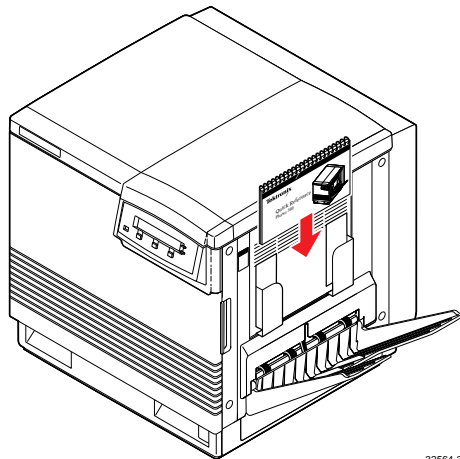

32564-34

Adding paper or transparencies

The printer is shipped with a PAPER tray (either A/Letter-size or A4-size) installed.

Remove the PAPER tray

1. Pull the tray out of the printer's right side.

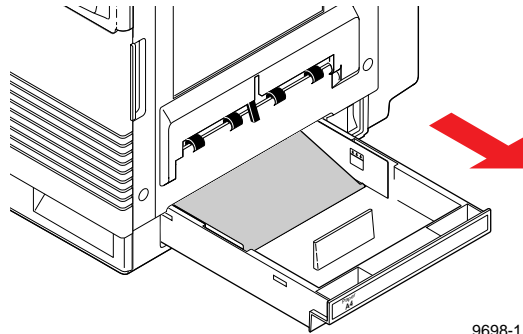

9698-11

2. Remove all the packaging materials from inside the tray; refer to the instruction sheet attached to the tray.

Types and sizes of media trays

The printer uses five unique media trays, as well as the multi-purpose feeder for any media type:

Tray	Media Type		Size
A/Letter	Paper	<i>standard</i>	8.5 x 11 in.
A/Letter	Transparency	<i>optional</i>	
A4	Paper	<i>optional</i>	210 x 297 mm
A4	Transparency	<i>optional</i>	
Legal	Paper	<i>optional</i>	8.5 x 14 in. 216 x 356 mm
Multi-Purpose Feeder	Paper	<i>standard</i>	3.5 x 10 in. to 8.5 x 14 in.
	Transparency		8.5 x 11 in.
	Specialty media		3.5 x 10 in. to 8.5 x 14 in. 89 x 254 mm to 216 x 356 mm

Note *For the best print quality, make sure that you load the correct media; each tray is designed and labeled for only Paper or Transparency. Although the printer will still print if you load the wrong media type in a tray, the print quality will suffer.*

If you have the Lower Tray Assembly installed and you wish to use the automatic tray-switching feature (for example, for a large print job), make sure that all trays in the printer at any one time are loaded with the same media type and size.

Multi-Purpose Feeder

For instructions on loading media into and printing from the Multi-Purpose Feeder, refer to “Using the Multi-Purpose Feeder” on page 4-40.

Loading media

If you ordered additional media trays, or if you ordered a Lower Tray Assembly (which includes a TRANSPARENCY tray and PAPER tray), each tray arrives in its own shipping box. Unpack each tray from its box and remove all packaging material from inside the tray(s); refer to the instruction sheet inside each tray.

Follow these steps to load media in any of the trays.

Note For complete information on loading all types of media in the trays and the Multi-Purpose Feeder, refer to “All about media” on page 4-30.

1. If you have not already done so, push down on the media tray’s metal plate until it clicks, locking it in place.

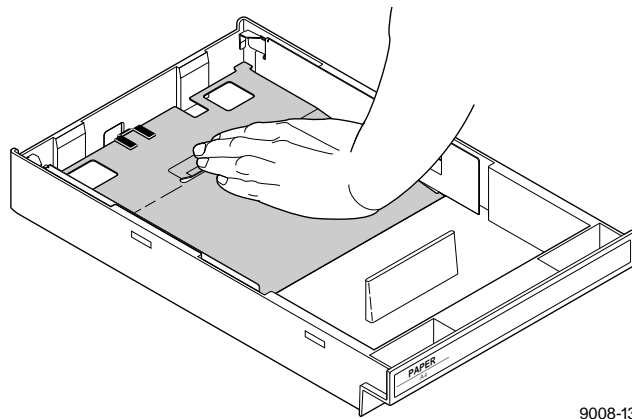

9008-13

Caution To keep your printer in good working order, always use clean media.

2. Fan the paper or transparencies, but be careful not to leave fingerprints, which can result in a smudged print.

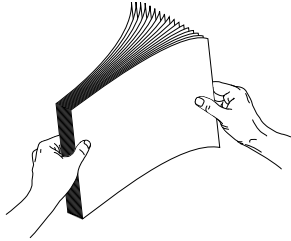

9014-36

3. Place paper or transparencies in the tray under the hooks.
4. If loading transparencies, load them so that the notched corner (4) is placed closest to the media level label (5). Refer to “Loading transparencies” on page 4-38 for more details.
5. You can load approximately 250 sheets of paper or 100 sheets of transparency film. Use the label on the inside of the tray as a reference for the proper amount of media.

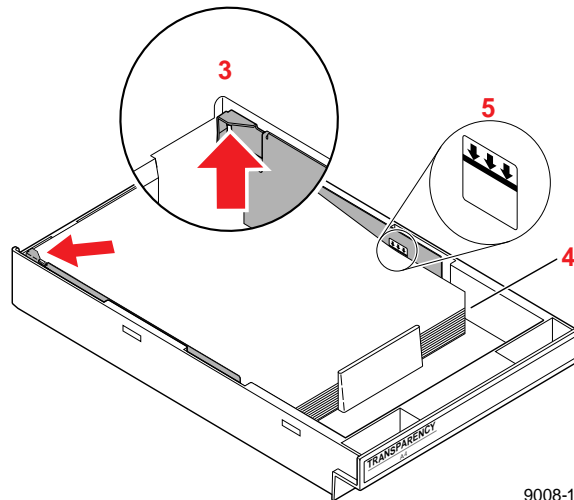

9008-14

6. If you have a single media tray

Slide the PAPER tray completely into the slot.

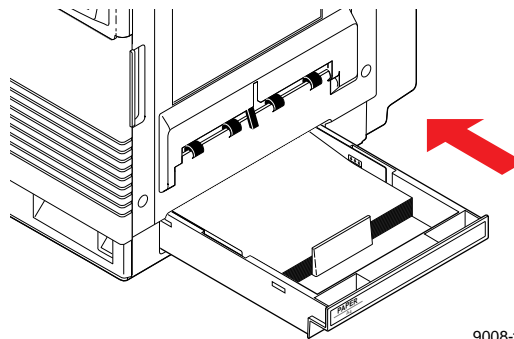

9008-15

If you have a Lower Tray Assembly

Install a media tray into each of the three slots.

Note A PAPER tray can be installed in any of the three tray slots (A, B, and C); however, for best results, the TRANSPARENCY tray should only be inserted in the upper (A) and middle (B) tray slots.

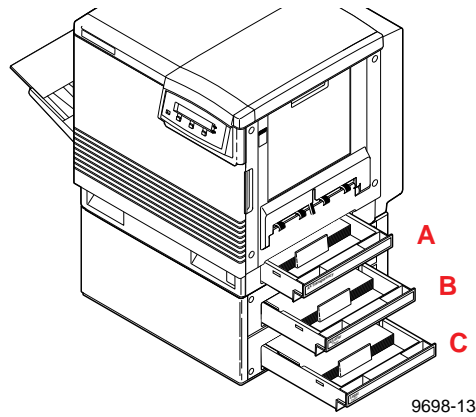

Connecting the printer

Printer ports

The printer is shipped with a SCSI port and parallel port on the printer's rear panel. Additionally, the printer can support one optional PhaserShare™ network card. All ports and network protocols are simultaneously active. The printer accepts print jobs on a first-come, first-served basis.

Note See “Printer interface cables and adapters” on page 9-4 about ordering cables for connecting the printer.

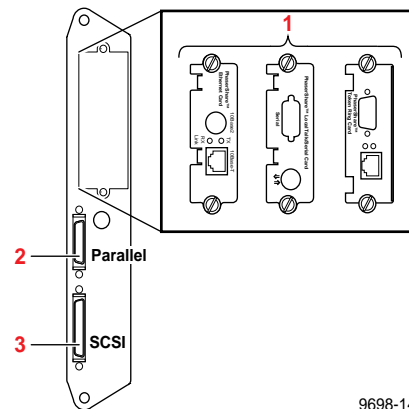

9698-14

1. **PhaserShare card (optional)** The printer accepts one of the following:
 - PhaserShare Ethernet card supporting Novell NetWare, EtherTalk, TCP/IP, Telnet and FTP protocols.
 - PhaserShare Token Ring card supporting Novell NetWare, TokenTalk, TCP/IP, Telnet and FTP protocols.
 - PhaserShare LocalTalk/serial card.

The *PhaserShare Network Cards and Software System Administrator Manual* contains all the information necessary for configuring and using the optional network interfaces. Refer to “PhaserShare network cards” on page 9-8 for ordering information.

2. **Parallel (standard)** The printer supports a standard (uni-directional) parallel port. The port can also be set for bi-directional communications using downloadable utility files, available on the printer's CD-ROM, diskettes, or from the Tektronix World Wide Web site (http://www.tek.com/Color_Printers/)
- Use a high-density bi-directional parallel cable, available from most computer cable vendors; or order a 36-pin high-density printer to 25-pin DSUB PC cable from Tektronix (order number: 012-1468-00). Otherwise, you can use a 36-pin to 36-pin parallel cable and the parallel adapter supplied with the printer.
 - Connect a parallel interface cable to your computer and to the printer's parallel port:

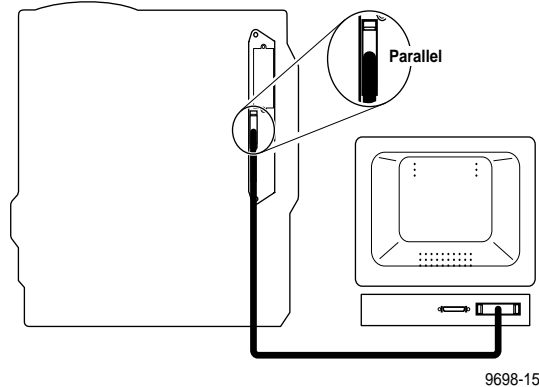

9698-15

3. **SCSI (standard)** For connecting these optional peripheral devices:
- **Phaser Copystation** To set up and connect the Phaser Copystation to your printer, refer to Chapter 2 of the *Phaser Copystation User Manual*. Required SCSI ID numbers are 5 and 6. Refer to “Phaser Copystation accessory” on page 9-9 for ordering information.
 - **External SCSI hard disk** Provides additional storage for downloadable fonts or for printer collation with the Extended Features option. You can connect one or more SCSI external hard disks to the printer; available SCSI ID numbers are 0, 1, 2, 3, and 4. Refer to “SCSI hard disk” on page 9-10 for ordering information.
- Make sure that all SCSI devices are turned off before plugging or unplugging any cables.

Turning on the printer

After you have connected all the interface cables, you are ready to connect the power cord and turn on the printer.

Caution *To protect your printer from a power surge, make sure that the power switch on the printer is in the off position before plugging in the cord.*

1. Plug the power cord into the printer and into a grounded outlet.
2. Turn on the power to any peripherals you have connected (i.e., a SCSI disk or Phaser Copystation).
3. Wait about 10 seconds, then turn on the printer.

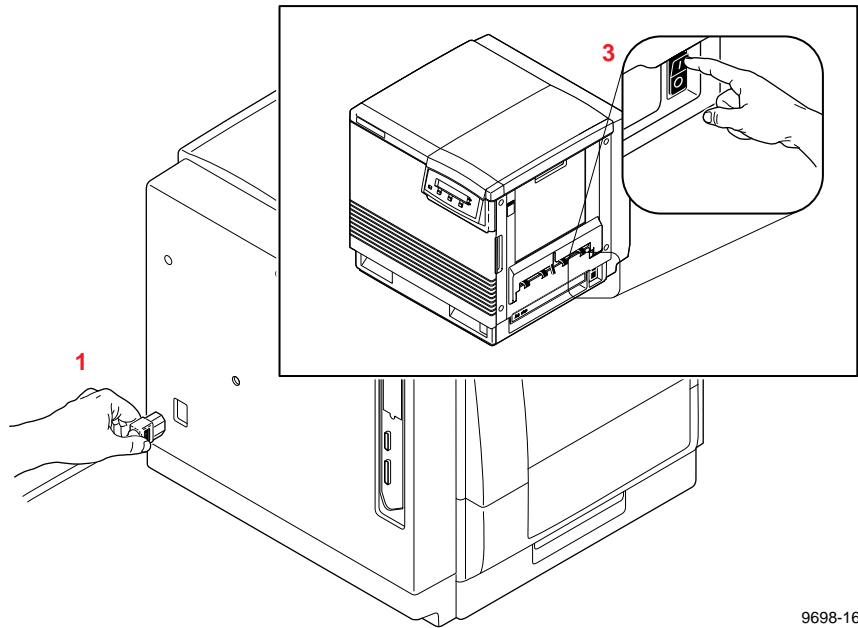

9698-16

What happens at power-up

- Both status indicators (power \odot and error \times) on the printer's front panel light briefly. Messages appear in the Liquid Crystal Display panel (LCD). The printer goes through a series of self-tests. The printer takes about 3 minutes to warm up and complete the self-tests (depending on the amount of memory installed).

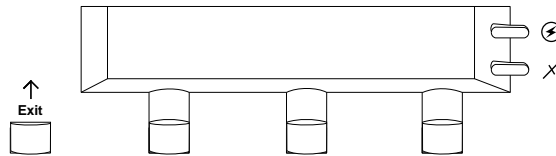

9008-43

- After the self-tests run successfully, the printer prints a Startup Page and, if the printer's copy count is between five and eight pages, prints a Registration Page. The Startup Page prints whenever you turn on or reset the printer.

Note *You can disable the Startup Page using either the front panel menu (refer to page 8-10 for instructions) or a software utility file provided on the printer's CD-ROM and the Tektronix World Wide Web site (refer to "Enabling and disabling the Startup Page" for details).*

When the printer is ready for operation

When the power-up sequence is complete, the green indicator is on steady (not blinking), the amber indicator is off, and the front panel message reads **Ready**.

Selecting a language for the front panel

By default, the front panel is set to display messages in English. If the Kanji font SIMM is installed, front panel messages display, by default, in Japanese. Use the printer's front panel to change the default to any of these languages: Spanish, French, German, Italian, English, or Japanese.

1. When the printer is on and the **Ready** message appears, press the **Menu** button. You see this message:

```
Help Pages
<---    ---> Menu
```

Pressing the left arrow button (<-->) scrolls backward through the selections; pressing the right arrow button (-->) scrolls forward through the selections; and **Menu** enters the currently displayed menu.

2. Using the left (<-->) or right (-->) arrow buttons, scroll through the selections until you see this message:

```
Language
<---    ---> Menu
```

3. Press the **Menu** button to enter the language selection menu. You see this message:

```
Language: English*
<---    ---> OK
```

where the asterisk (*) indicates the currently selected language.

4. Press the right arrow button until the display shows the language you want from these selections:

```
Language: English
Language: Español
Language: Français
Language: Deutsch
Language: Italiano
Language: (Japanese)
```

5. Press OK to select the language. Press the **Exit** button until **Ready** is displayed in the selected language.

Making a demonstration print

You can print a Demonstration Page to check that your printer is set up and operating correctly.

1. When the printer is on and the **Ready** message appears, press the **Menu** button. You see this message:

```
Help Pages
<---    --->  Menu
```

2. Press the **Menu** button. You see this message:

```
Consumables Page
<---    --->  Print
```

3. Using the left (<--)-or right (--->)arrow buttons, scroll through the selections until you see this message:

```
Demonstration Page
<---    --->  Print
```

4. Press the **Print** button to print the Demonstration Page.

Setting the Energy Star Timeout

When the printer is idle for a predetermined amount of time, it enters Energy Star mode, which reduces the power consumption and displays **standby** on the printer's front panel. The printer resumes normal power when it receives a signal, either from the front panel or a file being sent.

By default, the Energy Star mode is enabled and its timeout is set to 1 hour. For normal office environments, it is recommended that you set the timeout to 3 hours. To change this setting, follow these steps.

1. When the printer is on and the **Ready** message appears, press the **Menu** button. You see this message:

```
Help Pages
<---    --->  Menu
```

2. Scroll through the selections until you see this message:

```
Printer Defaults
<---    --->  Menu
```

3. Press the **Menu** button.

4. Scroll through the selections until you see this message:

```
Energy Star Timeout
<---    --->  Menu
```

5. Press the **Menu** button. The screen displays this message:

```
Timeout:1 hrs  *
<---    --->  OK
```

where the asterisk (*) indicates the currently selected timeout value.

6. Press the right arrow button to increment the value, until the display reads:

```
Timeout:3 hrs  *
<---    --->  OK
```

7. Press OK to select the displayed value. Press the  button until **Ready** is displayed.

Installing Printer Software

Packaged with your printer are a CD-ROM and a set of diskettes that contain the software you need to use the printer. Included are automatic installer applications, drivers, printer description files (PPDs), color sampler charts, utility files, and user documentation.

- For PC platforms, turn to page 3-1.
- For Macintosh platforms, turn to page 3-16.
- For workstations, turn to page 3-22.

PC/Windows software

Overview

These are the basic steps for software installation. Make a note of this information and refer to it during the on-screen installation procedure.

1. What is your printer's configuration? Look on the printer's Startup Page:

Extended Features: No	Phaser 560 - Base version
Extended Features: Yes	Phaser 560 - Extended version
2. To which port is your printer connected?

Installing printer software for Windows 95

Note *If you are installing from floppy diskettes, you may need more than one diskette depending on your Windows system. Keep all of the printer's diskettes handy during the installation, and insert each diskette when you are prompted by the installation program.*

1. Insert either the printer's CD-ROM or the Windows Disk 1 into the appropriate drive on your computer.
2. Click the Start icon in the taskbar, and select Run.
3. Type in the drive for the CD-ROM or diskette, type *SETUP.EXE*, and click OK.
4. Click Next in the two introduction screens in the *Installer*.
5. In the Select Installation Type dialog box, select either Easy Installation or Custom Installation, and click Next.

Easy Installation	Custom Installation
<p>The following files are copied to your hard disk:</p> <ul style="list-style-type: none">■ QuarkXPress PDF (installs an application-specific printer description file)■ PhaserPrint Plug-in for Photoshop (installs an application-specific plug-in, if the application is found)■ Samplers (installs color sampler charts and a fonts sampler)	<ol style="list-style-type: none">1. In the Driver Installation dialog box, select from the following options:<ul style="list-style-type: none">■ Drivers/PPDs (installs driver files and printer description files)■ QuarkXPress PDF (installs an application-specific printer description file)■ PhaserPrint Plug-in for Photoshop (installs an application-specific plug-in, if the application is found)2. Click Next.3. In the Custom Install: Select Utilities dialog box, select from the following options:<ul style="list-style-type: none">■ Printer Utilities (installs utility files for selecting printer features)■ Network Utilities (installs utility files for using the printer on a network)■ Samplers (installs color sampler charts and a fonts sampler)<p><i>Use the default Destination Directory or click Browse.</i></p>4. Click Next.5. Files are copied to your hard disk.

6. The Finish Installation dialog box contains instructions for completing the printer software setup; click Next. The Add Printer Wizard program is automatically launched.
7. In the Add Printer Wizard, click Next in the opening dialog box.
8. Select your printer's connection, either Local Printer or Network Printer, and click Next.
9. In the Manufacturers/Printers dialog box, click Have Disk.
10. Type in the drive for the CD-ROM or diskette, and click OK.
11. Select your printer, and click Next:
 - Tektronix Phaser 560 (standard printer configuration)
 - Tektronix Phaser 560 Extended (Extended Features option)

If you are not sure which version of the printer you have, check the printer's startup page for Extended Features: Yes or No.
12. Select the port your printer is connected to, and click Next.
13. Enter a name for the printer, and select the Phaser 560 as the default printer if desired, and click Next.
14. Decide if you want to print a test page, Yes or No, and click Finish.
15. In the Installation Completed dialog box, click Finish.
16. You may see a Restart Windows dialog box if the system needs to update some files. Decide if you want to restart now or later, and click OK.

Note See the "Adobe PostScript Printer Driver User Guide" on the printer's CD-ROM (*USERGUIDE.PDF*) for detailed information on the AdobePS 4 driver.

Installing printer software for Windows NT 4.0

Note *If you are installing from floppy diskettes, you may need more than one diskette depending on your Windows system. Keep all of the printer's diskettes handy during the installation, and insert each diskette when you are prompted by the installation program.*

1. Insert either the printer's CD-ROM or the Windows Disk 1 into the appropriate drive on your computer.
2. Click the Start icon in the taskbar, and select Run.
3. Type in the drive for the CD-ROM or diskette, type *SETUP.EXE*, and click OK.
4. Click Next in the two introduction screens in the *Installer*.
5. In the Select Installation Type dialog box, select either Easy Installation or Custom Installation, and click Next.

Easy Installation	Custom Installation
<p>The following files are copied to your hard disk:</p> <ul style="list-style-type: none">■ QuarkXPress PDF (installs an application-specific printer description file)■ PhaserPrint Plug-in for Photoshop (installs an application-specific plug-in, if the application is found)■ Samplers (installs color sampler charts and a fonts sampler)	<ol style="list-style-type: none">1. In the Driver Installation dialog box, select from the following options:<ul style="list-style-type: none">■ Drivers/PPDs (installs driver files and printer description files)■ QuarkXPress PDF (installs an application-specific printer description file)■ PhaserPrint Plug-in for Photoshop (installs an application-specific plug-in, if the application is found)2. Click Next.3. In the Custom Install: Select Utilities dialog box, select from the following options:<ul style="list-style-type: none">■ Printer Utilities (installs utility files for selecting printer features)■ Network Utilities (installs utility files for using the printer on a network)■ Samplers (installs color sampler charts and a fonts sampler) <i>Use the default Destination Directory or click Browse.</i>4. Click Next.5. Files are copied to your hard disk.

6. The Finish Installation dialog box contains instructions for completing the printer software setup; click Next. The Add Printer Wizard program is automatically launched.
7. In the Add Printer Wizard, click Next in the opening dialog box.
8. Select printer management, either My computer or Network printer server, and click Next.
9. Select the port your printer is connected to, and click Next.
10. In the Manufacturers/Printers dialog box, click Have Disk.
11. Type in the drive for the CD-ROM or diskette, and click OK.
12. Select your printer, and click Next:
 - Tektronix Phaser 560 (standard printer configuration)
 - Tektronix Phaser 560 Extended (Extended Features option)

If you are not sure which version of the printer you have, check the printer's startup page for Extended Features: Yes or No.
13. Enter a name for the printer, and select the Phaser 560 as the default printer if desired, and click Next.
14. Decide if you want to share the printer, Shared or Not shared, and click Next.
15. Decide if you want to print a test page, Yes or No, and click Finish.
16. In the Installation Completed dialog box, click Finish.
17. You may see a Restart Windows dialog box if the system needs to update some files. Decide if you want to restart now or later, and click OK.

Installing printer software for Windows NT 3.51

Note *If you are installing from floppy diskettes, you may need more than one diskette depending on your Windows system. Keep all of the printer's diskettes handy during the installation, and insert each diskette when you are prompted by the installation program.*

1. Insert either the printer's CD-ROM or the Windows Disk 1 into the appropriate drive on your computer.
2. Select Run from the File menu.
3. Type in the drive for the CD-ROM or diskette, type *SETUP.EXE*, and click OK.
4. Click Next in the two introduction screens in the *Installer*.
5. In the Select Installation Type dialog box, select either Easy Installation or Custom Installation, and click Next.

Easy Install	Custom Install
<p>The following files are copied to your hard disk:</p> <ul style="list-style-type: none">■ QuarkXPress PDF (installs an application-specific printer description file)■ PhaserPrint Plug-in for Photoshop (installs an application-specific plug-in, if the application is found)■ Samplers (installs color sampler charts and a fonts sampler)	<ol style="list-style-type: none">1. In the Driver Installation dialog box, select from the following options:<ul style="list-style-type: none">■ Drivers/PPDs (installs driver files and printer description files)■ QuarkXPress PDF (installs an application-specific printer description file)■ PhaserPrint Plug-in for Photoshop (installs an application-specific plug-in, if the application is found)2. Click Next.3. In the Custom Install: Select Utilities dialog box, select from the following options:<ul style="list-style-type: none">■ Printer Utilities (installs utility files for selecting printer features)■ Network Utilities (installs utility files for using the printer on a network)■ Samplers (installs color sampler charts and a fonts sampler) <i>Use the default Destination Directory or click Browse.</i>4. Click Next.5. Files are copied to your hard disk.

6. The Finish Installation dialog box contains instructions for completing the printer software setup; click Next. The Print Manager opens automatically.
7. From the Printer menu select Create Printer.
8. In the Create Printer dialog box, under Driver, select Other.
9. Type in the drive for the printer's CD-ROM or diskette, click OK.
10. In the Select Driver dialog box, under Printer Driver, select your Phaser 560 printer, and click OK:
 - Tektronix Phaser 560 Extended (Extended Features option)
 - Tektronix Phaser 560 (standard printer configuration)

If you are not sure which version of the printer you have, check the printer's startup page for Extended Features: Yes or No.
11. In the Create Printer dialog box, fill in the other fields as desired, then click OK.
12. Select options in the PostScript Printer Setup dialog box, and click OK.

Enabling the Use Printer Halftoning option is recommended.
13. In the Print Manager, from the Printer menu select Exit.
14. In the Installation Completed dialog box, click Finish.

Installing printer software for Windows 3.1

Note *If you are installing from floppy diskettes, you may need more than one diskette depending on your Windows system. Keep all of the printer's diskettes handy during the installation, and insert each diskette when you are prompted by the installation program. The Tektronix driver is available on both CD-ROM and diskette; the AdobePS3 driver is available on CD-ROM only.*

1. Insert either the printer's CD-ROM or the Windows Disk 1 into the appropriate drive on your computer.
2. Select Run from the File menu.
3. Type in the drive for the CD-ROM or diskette, type *SETUP.EXE*, and click OK.
4. Click Next in the two introduction screens in the *Installer*.
5. In the Select Installation Type dialog box, select either Easy Installation or Custom Installation, and click Next.

Easy Installation

The following files are copied to your hard disk:

- **Tektronix Printer Driver**
 - **QuarkXPress PDF**
(installs an application-specific printer description file)
 - **Samplers**
(installs color sampler charts and a fonts sampler)
-

Custom Installation

1. In the **Driver Installation** dialog box, select from the following options:

- **Drivers/PPDs**
(installs driver files and printer description files)
- **QuarkXPress PDF**
(installs an application-specific printer description file)

2. Click **Next**.

3. If you selected **Drivers/PPDs** in the previous window, the **Custom Install: Select Drivers** dialog box appears. Select one of the following drivers and click **Next**:

- **Adobe Printer Driver for Windows 3.1**
- **Tektronix Printer Driver for Windows 3.1**

Note: *The Tektronix Printer Driver for Windows 3.1 must be installed in the Windows directory (default Destination Directory). Do not change the Destination Directory when installing the Tektronix driver unless you are installing the driver on a network and you know the location of the Windows directory on the network drive.*

4. In the **Custom Install: Select Utilities** dialog box, select from the following options:

- **Printer Utilities**
(installs utility files for selecting printer features)
- **Network Utilities**
(installs utility files for using the printer on a network)
- **Samplers**
(installs color sampler charts and a fonts sampler)

Use the default Destination Directory or click Browse.

5. Click **Next**.

Files are copied to your hard disk.

6. If you are installing the Tektronix driver, select your printer type and click **Next**:

- Tektronix Phaser 560 Base version (printer's standard configuration)
- Tektronix Phaser 560 Extended version (Extended Features option)

If you are not sure which version of the printer you have, check the printer's startup page for Extended Features: Yes or No.

7. The **Finish Installation** dialog box contains instructions for completing the printer software setup; click **Next**.

8. In the **Installation Completed** dialog box, click **Finish**.

9. Go on to the setup instructions (refer to the next page).

3 *Installing Printer Software*

Tektronix Driver for Windows 3.1: Setup instructions

If you selected **Easy Installation**, or if you selected the **Tektronix Driver for Windows 3.1** in the **Custom Installation**, continue with the following instructions:

1. Open the Windows **Control Panel**.
 2. Open the **Printers** dialog box.
 3. Under **Installed Printers**, select your Phaser 560 printer, click **Connect**:
 - **Tek Phaser 560 (TekColor) Ext**
(Extended Features option)
 - **Tek Phaser 560 (TekColor)**
(standard printer configuration)
 4. Select the printer's port, click **OK**.
-

AdobePS 3 Driver for Windows 3.1: Setup instructions

If you selected the **AdobePS 3 Driver for Windows 3.1** in the **Custom Installation**, continue with the following instructions:

1. In the Adobe installer, click **Read** or **Skip** in the **README.WRI** dialog box to start the installation.
 2. Click **Continue** in the **PostScript Printer Driver Setup** dialog box. Files are copied to your computer.
 3. Click the **Restart Windows** button in the dialog box that appears.
 4. After Windows restarts, the **Install PostScript Printer from PPD** dialog box opens. Select your printer in the list and click **Install**:
 - **Tektronix Phaser 560 Extended**
(Extended Features option)
 - **Tektronix Phaser 560**
(standard printer configuration)
 5. Click **OK** in the next dialog box.
 6. Click **Close** in the **Install PostScript Printer from PPD** dialog box.
 7. Click **OK** in the information dialog box.
 8. In the **Control Panel**, double-click **Printers**.
 9. In the **Printers** dialog box, select the printer you just installed, and click **Connect**.
 10. In the **Connect** dialog box, select the port the printer is connected to, and click **OK**.
-

Setting up the printer on a network (Windows NT 3.5 and 3.51)

TCP/IP connection

Note *Windows NT 3.5 and 3.51 include network software called Services for Macintosh (AppleTalk) and TCP/IP print services (for TCP/IP; lpr print services). Refer to your Windows NT manual for instructions on installing this network software. After this software is loaded, follow these steps:*

1. Select Create a new printer in the Print Manager; select the appropriate printer driver.
2. Select Other in the Print to field of the Printer Properties dialog box.
3. Select LPR Port for Available Print Monitors; click OK.
4. For Name or address of host providing lpd, type your printer's IP address (or Host name if known to the network).

Note *The printer's IP address may be available on the printer's Configuration Page. If not, ask your network administrator.*

5. For Name of printer on that machine, type in one of the following (use capital letters):
PS for PostScript
AUTO for automatic selection
6. Click OK to complete the installation.

AppleTalk connection

Note *Windows NT 3.5 and 3.51 include network software called Services for Macintosh (AppleTalk) and TCP/IP print services (for TCP/IP; lpr print services). Refer to your Windows NT manual for instructions on installing this network software. After this software is loaded, follow these steps:*

1. Select Create a new printer in the Print Manager; select the appropriate printer driver.
2. Select Other in the Print to field of the Printer Properties dialog box.
3. Select AppleTalk Printing Devices for Available Print Monitors; click OK.
4. Double-click on the appropriate zone (if there are multiple AppleTalk zones).
Select your Tektronix printer and click OK.
5. At the prompt *Do you want to capture this AppleTalk Printing Device?*, click No.

Note *Clicking Yes hides the printer from regular Macintosh users, forcing them to use NT Server as a spooler, as long as NT Server allows sharing of this printer.*

6. Click OK to complete the installation.

Setting up the printer on a network (Windows NT 4.0)

To add or update the driver on a Windows NT 4.0 Server or Workstation

Note *You will need the printer's IP address for this procedure; it may be available on the printer's Configuration Page. If not, ask your network administrator.*

1. Log-in as Administrator or a user with administrator access privileges.
2. Click on the Start button. Select Settings, then select Printer from the submenu.
3. Double-click on the Add Printer icon In the Printers dialog box.
4. Select one of these options, then click Next:

My Computer	Locally installed and managed printer
Network	Networked printer
5. If this is a locally connected printer, click on the port that the printer is connected to:

LPTx	Parallel-printer connection
COM	Serial-connected printer
Add Port	Networked printer

Recommended: connect via TCP/IP by double-clicking on the LPR Port.

Note *If the LPR port is not listed in this box, the Microsoft TCP/IP Printing Services needs to be added to the NT machine. The original Windows NT distribution diskettes are needed during installation. Click Start, Settings, Control Panel, Network. Click on the Services tab, then click Add. Select Microsoft TCP/IP Printing, then click OK and install this service.*

If Microsoft TCP/IP Printing Services is not listed in the options box, install the TCP/IP protocol on the server. This is done from the Control Panel/Network box. Click on the Protocols tab and click Add. Select TCP/IP Protocol and click OK. To apply these changes, restart the Windows NT 4.0 server.

6. Enter the printer's IP address in the box labeled Name or address of server providing lpd.

7. In the box marked Name of printer or print queue on that server, enter PS (for PostScript) in uppercase, then click OK.
8. Click Close in the Printer Ports box.
9. In the Add Printer Wizard dialog box, click the box next to this new port; then click Next.
10. In the Add Printer Wizard dialog box, click Have Disk to add a new Tektronix driver.
11. Type in the path name (CD-ROM or diskette) to the driver files, then click OK.
12. Select the printer model and click Next.
13. If prompted that a driver is already installed for this printer, select Replace existing driver, then click Next.
14. Type in the printer's name (any name you want). Click the appropriate box to use this printer as the default.
Click Next.
15. Check one of the following options, then click Next:

Shared	To share the printer on the network (click on all platforms that may use this printer.)
Not shared	If the printer is a local printer only
16. Select one of these options, then click Finish:

Yes	Print a Test Page	Recommended
No	Do not print a Test Page	
17. If you are using the printer's CD-ROM, *and* you selected Shared in Step 15, a message appears asking for the location of printer files. Type in the CD-ROM drive followed by `\PPDS95NT.DRV`, and click OK. Files are copied to your hard disk.
18. If you printed a Test Page, check if it printed; then click OK.

Macintosh software

Overview for Mac™ OS platforms

These are the basic steps and information necessary for software installation. Make a note of this information and refer to it during the on-screen installation procedure.

1. What is your printer's configuration? Look on the printer's Startup Page:

Extended Features: No	Phaser 560 - Base version
Extended Features: Yes	Phaser 560 - Extended version

2. Decide which drivers you want to install:
 - LaserWriter 8 driver
 - Phaser 560 driver
 - Phaser 560 GX driver

3. Install the printer's software according to your operating system's specific procedures.
 - a. Select one:

Easy Install	A pre-defined list of drivers, PPDs, utility files
Custom Install	A custom-selected list of drivers, PPDs, utility files, software applications
 - b. Follow the installer's on-screen prompts.

4. Follow the instructions for setting up the driver you installed.

To begin the installation procedures: Turn to page 3-18 now.

Custom Install or Easy Install?

Installer options	Software	Description	Installed folder
Custom Install	Easy Install		
	LaserWriter 8 Driver	Driver for use with all (non-GX) Macintosh systems.	<i>System Folder:Extensions</i>
	Phaser 560 Driver	Custom driver based on the LaserWriter 7.1.2 printer driver.	<i>System Folder: Extensions</i>
	Phaser 560 GX Driver	Driver for use with QuickDraw GX.	<i>System Folder: Extensions</i>
	Printer Descriptions	PPDs for use with drivers and applications.	<i>System Folder:Extensions: Printer Descriptions</i>
	ColorSync Profile	Printer profile for use with ColorSync 2.0.	<i>System Folder: Preferences: ColorSync™ Profiles</i>
	Samplers	Color sampler charts and a fonts sampler.	<i>PhaserTools:Samplers</i>
	QuarkXPress PDF File	File for use with the QuarkXPress application.	<i>QuarkXPress application folder: PDF</i>
	PhaserPrint Photoshop Plug-in	Custom plug-in for printing from Adobe Photoshop.	<i>Photoshop application folder</i>
	Screen Fonts	Screen fonts to match the printer's fonts.	<i>System Folder:Fonts</i>
	Printer Utilities	Printer utility files for controlling printer features.	<i>PhaserTools: Printer Utilities</i>
	Network Utilities *	Utility files for using the printer on a network.	<i>PhaserTools:Network Utilities</i>
PANTONE® Files *	PANTONE® Color library files and sampler chart.	<i>PhaserTools:PANTONE Files</i>	

* Available only on the printer's CD-ROM.

3 *Installing Printer Software*

Installing printer software for Macintosh

Use the installer application on the printer's CD-ROM or diskettes to install the printer's standard software. Then, continue with driver-specific setup instructions for the driver you are using.

1. Insert either the printer's CD-ROM or the first Macintosh diskette into the appropriate drive on your computer.
2. Double-click the Phaser 560 Installer icon. Click Continue until the Easy Install window appears.
3. Select Easy Install or Custom Install (see page 3-17 for the list of files in each):

For Easy Install

- a. Click Install.
- b. For details on each item to be installed, click Read Me.

For Custom Install:

- a. Select Custom Install.
- b. Select individual items to install.
- c. Click the ⓘ buttons for information on each item.
- d. Click Install to install the selected items.

Setting up the Phaser 560 printer driver

Use with System Software 6.0.7, or 7.0 and later.

1. Select Chooser from the Apple menu after installing the printer's software (page 3-18).
2. Click on the icon of the Phaser 560 printer driver (on the left side of the Chooser).
3. Click on the Zone for your printer. See your network administrator if you have questions.
4. Select your printer from the list of printers on the right side of the Chooser. If it is not in the list, check your hardware connections and which zone you have selected in the Chooser.
5. Close the Chooser.

3 *Installing Printer Software*

Setting up the Apple LaserWriter 8 printer driver

1. Select Chooser from the Apple menu after installing the printer's software (page 3-18).
2. Click on the icon of the LaserWriter 8 printer driver (on the left side of the Chooser).
3. Click on the Zone for your printer. See your network administrator if you have questions.
4. Select your printer from the list of printers on the right side of the Chooser. If it is not in the list, check your hardware connections and which zone you have selected in the Chooser.
5. Click Setup. Click on the PPD for your printer: *

TKPH5601.PPD	Standard configuration
TKP560P1.PPD	Extended Features option
6. Click Select.
7. Close the Chooser.

* Check the Startup Page for your printer's configuration information.

Setting up the Phaser 560 GX printer driver

Refer to the on-line manual on the printer's CD-ROM.

1. Select **Chooser** from the **Apple** menu after installing the printer's software (page 3-18).
2. Click on the icon of the Phaser 560 GX printer driver (on the left side of the Chooser).
3. Click on the **Zone** for your printer. See your network administrator if you have questions.
4. Select your printer from the list of printers on the right side of the Chooser. If it is not in the list, check your hardware connections and which zone you have selected in the Chooser.
5. In the **Connect via** field's pop-up menu, select your printer's communication method:

AppleTalk	Standard network connection
Servers	Shared desktop printer
6. Click **Create** to create a desktop printer. An icon of the printer appears on the desktop.
7. Close the Chooser.

Workstation software

Downloadable printer utility files

Note *Refer to the on-line manuals on the printer's CD-ROM for more information on printing from a workstation.*

These utility files on the printer's CD-ROM and diskettes can be used with UNIX and VMS workstations; they let you set up your spooling system to select the following:

- Print-quality mode
- Color correction mode
- Default tray
- Other printer features

UNIX workstation users can access utility files in any of the following ways:

- If your system includes a CD-ROM drive, install the files from the printer's CD-ROM. Look in the *.bin* directory for workstation-specific files.
- Mount the printer's PC diskette 1 and copy the files to your workstation's hard drive.
- Access the Tektronix anonymous ftp site on the Internet at <ftp.tek.com>.
- Download utility files from the Tektronix Bulletin Board Service (BBS); refer to page 7-1.
- Access the Tektronix World Wide Web server on the Internet:

http://www.tek.com/Color_Printers/	Home page
<a href="ftp://ftp.tek.com/bbs/<platform>/560">ftp://ftp.tek.com/bbs/<platform>/560	Utility files

- Access sample scripts that are available on-line; refer to page 7-1 for information.

PhaserPrint for UNIX software (demo)

Optional PhaserPrint™ for UNIX software provides:

- Driver-selectable printer options
- Fast raster file printing to Tektronix color printers
- Fast screen-copy printing to Tektronix color printers

Note *The printer's CD-ROM contains a demonstration copy of the PhaserPrint for UNIX software and an on-line instruction guide in the UNIXDEMO directory. For order information, refer to page 9-10.*

Printing Basics

You can print to your printer from Windows-based PCs (personal computers), Macintosh computers, and workstations. Make sure that your printer is set up with the appropriate interface port; refer to “Connecting the printer” on page 2-18. If you haven’t already installed the printer’s software, refer to “Installing Printer Software” on page 3-1 for instructions before continuing.

Refer to the following topics for specific information:

- “Printing from a PC” on page 4-1
- “Printing from a Macintosh” on page 4-12
- “Printing from a workstation” on page 4-18

Note *Refer to the on-line manuals on the printer’s CD-ROM for information on “Printing from DOS.”*

Printing from a PC

You can print from a PC with or without a printer driver. The supported drivers allow you to select printing features right from your computer. Refer to page 4-2 for a reference table of printing features and to page 4-20 for detailed information.

Without a supported driver, you can make some printing selections from the printer’s front panel. Refer to page 4-21 for a list of front panel selections and to page 8-1 for instructions on using the front panel.

For information on selecting print options with utility files, refer to the online documents on the printer’s CD-ROM or the Tektronix World Wide Web site at http://www.tek.com/Color_Printers/

4 Printing Basics

Print features quick reference: Windows printer drivers

Feature	Page #	Operating System			
		Windows 3.1		Windows 95	Windows NT 4.0
		AdobePS 3 PostScript	Tektronix driver	Microsoft PostScript AdobePS 4 PostScript	PostScript driver
Media size <ul style="list-style-type: none"> ■ Letter* ■ Legal ■ A4 	page 4-30	Paper tab ↳ Paper Size	Setup ↳ Paper Size	Properties ↳ Paper tab ↳ Paper Size	Properties ↳ Advanced tab ↳ Paper/Output ↳ Paper Size
Tray selection <ul style="list-style-type: none"> ■ Paper* ■ Transparency ■ Upper ■ Middle † ■ Lower † ■ Multi-Purpose Tray ■ Multi-Purpose Manual Feed 	page 4-33, page 4-35	Paper tab ↳ Paper Source Note: to see all trays in the list, go to the Features tab and select Optional Lower Trays Installed .	Setup ↳ Paper Source	Properties ↳ Paper tab ↳ Paper Source	Properties ↳ Advanced tab ↳ Paper/Output ↳ Paper Source Note: to see all trays in the list, go to the Device Settings tab, to Installable Options , click on Optional Lower Trays , and click Installed .
Multi-Purpose Manual Feed Media <ul style="list-style-type: none"> ■ Paper* ■ Paper 2nd Side ■ Transparency ■ Coated Paper ■ Card or Envelope ■ Label ■ Fabric Transfer 	page 4-33, page 4-40	Features tab ↳ MP Manual Feed Media	Setup ↳ Options ↳ Printer Features ↳ MP Manual Feed Media	Properties ↳ Device Options ↳ Printer Features ↳ MP Manual Feed Media	Properties ↳ Advanced tab ↳ Printer features ↳ MP Manual Feed Media
Print quality modes <ul style="list-style-type: none"> ■ Fast Monochrome ■ Fast Color ■ Presentation ■ Standard * ■ Premium ‡ 	page 4-23	Features tab ↳ Print Quality	Setup ↳ Options ↳ Printer Features ↳ Print Quality	Properties ↳ Device Options tab ↳ Printer features ↳ Print Quality	Properties ↳ Advanced tab ↳ Printer features ↳ Print Quality

* Factory default setting.

† Available with the Lower Tray Assembly.

‡ Available with the Extended Features option.

Print features quick reference: Windows printer drivers (cont'd.)

Feature	Page #	Operating System			
		<u>Windows 3.1</u>		<u>Windows 95</u>	<u>Windows NT 4.0</u>
		AdobePS 3 PostScript	Tektronix driver	Microsoft PostScript AdobePS 4 PostScript	PostScript driver
Color correction <ul style="list-style-type: none"> ■ Automatic * ■ None ■ Vivid Color ■ Simulate Display ■ SWOP Press ■ Euroscale Press ■ Commercial Press ■ Use Printer Setting 	page 4-24	Features tab ↳ Color Correction	Options ↳ Printer Features ↳ Color Correction	Properties ↳ Device Options tab ↳ Printer features ↳ Color Correction	Properties ↳ Advanced tab ↳ Printer features ↳ Color Correction
Quick Collate † <ul style="list-style-type: none"> ■ On ■ Off * 	page 5-8	Features tab ↳ Quick Collate	Options ↳ Printer Features ↳ Quick Collate	Properties ↳ Device Options tab ↳ Printer features ↳ Quick Collate	Properties ↳ Advanced tab ↳ Printer features ↳ Quick Collate
Check Print ‡ <ul style="list-style-type: none"> ■ On ■ Off * 	page 5-11	Features tab ↳ Check Print	Options ↳ Printer Features ↳ Check Print	Properties ↳ Device Options tab ↳ Printer features ↳ Check Print	Properties ↳ Advanced tab ↳ Printer features ↳ Check Print
Image Smoothing <ul style="list-style-type: none"> ■ On ■ Off * 	page 5-14	Features tab ↳ Image Smoothing	Options ↳ Printer Features ↳ Image Smoothing	Properties ↳ Device Options tab ↳ Printer features ↳ Image Smoothing	Properties ↳ Advanced tab ↳ Printer features ↳ Image Smoothing
Output Order <ul style="list-style-type: none"> ■ Face Up (on) * ■ Face Down (off) 	page 4-25	Features tab ↳ Output Order	Options ↳ Printer Features ↳ Output Order	Properties ↳ Device Options tab ↳ Printer features ↳ Output Order	Properties ↳ Advanced tab ↳ Printer features ↳ Output Order

* Factory default setting.

† Available with the Lower Tray Assembly.

‡ Available with the Extended Features option.

Using the AdobePS 4 driver with Windows 95

To select printing options in the AdobePS 4 driver, follow these steps:

1. In the Printers window, click the Phaser 560 printer icon with the right mouse button, then select Properties from the menu.
2. Click the following tabs to see printing options; refer to your Windows 95 documentation for more information on tabs and options.

Details For timeout settings and other options

- Set the Timeout settings. Refer to “Setting the timeouts” on page 4-11 for instructions.

Under PostScript Timeout values, leave Job Timeout set to 0. Set WaitTimeout to the default, 240 (4 minutes). Setting it higher ensures that you will not lose a multi-page job due to a timeout after the Transmission Retry alert message is displayed.

Paper For media options (sizes, types, and source)

Graphics For graphics options

- Refer to the on-line manuals on the printer’s CD-ROM for more information on host color correction.

Note *Use the Print Quality selections in the Device Options tab instead of the Resolution Options in the Graphics tab.*

Device Options For printer-specific options (color corrections)

- Select Installed for the optional Lower Tray Assembly if your printer has this accessory. You must make this selection for the optional media trays to be available under the Paper tab.
- Refer to the on-line manuals on the printer’s CD-ROM for more information on host color correction.

PostScript For PostScript-related options

Note *The PostScript header contains important PostScript information that must accompany each print job; it is not a banner page printed with each job. If an option is not selected, an error message is displayed on your computer screen and your job does not print.*

- Click *one* of the following in the PostScript header field:
 - Download header with each print job
This option downloads PostScript header information with each print job. This is the recommended setting.
 - Send Header Now
This button saves the PostScript header information in the printer. After selecting this button, select the Assume header is downloaded and retained option which makes print files a little smaller and faster than the first option, but you need to click the Send Header Now button every time the printer is turned off or reset.
- Click the Advanced button to see more options. Select Use PostScript Level 2 features. For faster printing, select Binary communications protocol under Data format. To ensure job integrity, select Send Ctrl-D before and after a job. Click OK when finished.

Using the Windows NT 4.0 PostScript driver

When using Microsoft Windows NT 4.0, make sure that you have first installed and set up a driver for a Phaser 560 printer (refer to page 3-4). Then, select printer features (such as TekColor color corrections) from the Windows NT driver.

Selecting printer options from the Control Panel

Note *Document properties set from an application always override document defaults set in the printer's Properties sheets. However, if an application does not set a document property (such as page orientation or paper size), the printer defaults to the document properties set in the printer's Document Properties sheets.*

To view a printer's Default Document Properties:

1. Open the *Printers* folder.
2. With the right mouse button, click on the printer's icon.
3. With the left mouse button, click on Document Defaults.
4. Click the Advanced tab to change any printer features, including TekColor.
5. Click the Page Setup tab to see other features.

Note *Select Installed for the optional Lower Tray Assembly if your printer has this accessory. You must make this selection for the optional media trays to be available under Document Defaults.*

Print command options in an application

Note *Changes to any of these settings override the Default Printer Properties settings in the Printers folder.*

1. Select Print from the File menu; the Print dialog box appears. You can select a different printer and other settings in this dialog box.
2. Click on the Properties button; the Printer Document Properties sheet appears.
3. Click the Advanced tab to change any printer features, including TekColor. This tab displays the same information as the Document Defaults Properties Advanced tab.
4. Click the Page Setup tab to see other features. This tab displays the same information as the Documents Defaults Properties Page Setup tab.

Page Setup options in an application

Note *If changing the Printer Driver settings through Page Setup causes problems with the application you are using, then change the Printer Driver settings through Print under the File menu, described in the previous topic.*

1. Select Page Setup from the File menu; the Page Setup dialog box appears.
2. Select Paper Size and Source.
3. Click on the Printer button; another Page Setup dialog box appears. You can select a different printer here.
4. Click on the Properties button; the Printer Document Properties sheet appears.
5. Click the Advanced tab to change any printer features, including TekColor. This tab displays the same information as the Document Defaults Properties Advanced tab.
6. Click the Page Setup tab to see other features. This tab displays the same information as the Document Default Properties Page Setup tab.

Note *Changes to any of these settings override the Defaults Printer Properties settings in the Printers folder.*

Using the Windows NT 3.5 and 3.51 PostScript driver

If you are using Microsoft Windows NT, follow the instructions on page 3-6 to set up a Windows NT PostScript driver with a Phaser 560 printer.

You can select printer page sizes in the driver for Windows NT applications, however, TekColor color corrections and other PostScript Level 2 features are not supported by the Windows NT driver. Refer to page 4-24 for instructions on selecting color corrections from the printer's front panel or from downloadable utility files.

Refer to your Microsoft Windows NT documentation for details on features in the Windows NT driver.

Using the Tektronix printer driver for Windows 3.1

To select printing options, follow these steps:

1. From the Control Panel, double-click the Printers icon.
2. In the Printers dialog box, choose your printer from the list of installed printers, then click the Setup button.

A dialog box appears with the name of the printer you selected across the top.

3. From the Setup dialog box, click the Options button to see the Options dialog box. Refer to your Microsoft Windows documentation for details on the options in this dialog box.
 - Make sure that the Color check box is *on* to print in color.
 - Select *one* of the following header options:
 - Make sure that the Send Header with Each Job check box is *on* (checked) to download PostScript header information with each print job. This is the recommended setting.
 - Click the Send Header button. In the Send Header dialog box, select either Printer or File, and click the Send Now button. This saves the PostScript header information in the printer. This option makes print files a little smaller and faster, but you need to click the Send Now button every time the printer is turned on.
4. From the Options dialog box, click the Advanced button to see the Advanced Options dialog box. Make sure the Use PostScript Level 2 Features check box is checked *on*.

Note *The Use PostScript Level 2 Features option affects the print time of bitmapped (raster) images by improving the image transfer time from the computer to the printer, and by improving the image processing time in the printer. This option is only available to applications that use this Tektronix driver with Tektronix PostScript Level 2 printers. When this box is checked, the Compress Bitmaps option is unavailable (grayed-out).*

5. Click OK to return to the Options dialog box.
6. In the Options dialog box, click the Printer Features button to see the Tektronix Printer Features dialog box. Make color correction, print quality, and other selections as desired. Use the MP Manual Feed Media menu to select specialty media or double-sided printing. Click OK to return to the Options dialog box.
7. Click OK to return to the dialog box that lists your printer's name across the top. Make the following printing selections: Paper Source, Paper Size, Orientation, Copies.

Note *You may want to set the number of copies from your application because the number of copies in the Setup dialog box remains the same until you change it again. Also, if you are printing multiple pages, make sure that the Transmission Retry (described on page 4-11) is set for at least 600 seconds (10 minutes).*

Using the Adobe PostScript driver for Windows 3.1

To select printing options, follow these steps:

1. From the Control Panel, double-click the Printers icon.
2. In the Printers dialog box, choose the Tektronix Phaser 560 printer, then click Setup. A dialog box appears with the printer's name across the top.
3. Click the following tabs to see printing options; refer to your Windows documentation for more information on tabs and options.

Paper For media options (sizes, types, and source)

Features For printer-specific options such as color correction.

- Set the Timeout settings. Refer to "Setting the timeouts" on page 4-11 for instructions.

PostScript For PostScript-related options

- In the Performance Options field, select the Use PostScript Level 2 Features option.
- Under PostScript Timeout values, leave Job Timeout set to 0. Leave the WaitTimeout set to the default, 240 (4 minutes). Setting it higher ensures that you will not lose a multi-page job due to a timeout after the Transmission Retry alert message is displayed.

Job Control For print job-related options

Note *The PostScript header contains important PostScript information that must accompany each print job; it is not a banner page printed with each job. If an option is not selected, an error message is displayed on your computer screen and your job does not print.*

- Click one of the following in the PostScript header field:
 - Download Each Job
This option downloads PostScript header information with each print job.
 - Already Downloaded
This saves the PostScript header information in the printer. After selecting this button, select the Download button. This option makes print files a little smaller and faster than the first option, but you need to click the Download button every time the printer is turned off or reset.
- For better performance, select the Binary Mode option.

Setting the timeouts

Each driver provides the ability to change default timeout settings. Refer to the documentation for your computer's operating system for information accessing these settings.

To access the timeout settings

Windows 95

1. In the Printers window, click the Phaser 560 printer icon.
2. Select Properties from the menu.
3. Click the Details tab.
4. Set the Timeout settings.

Windows 3.1

1. From the Control Panel, double-click Printers.
2. Select your printer and click either of the following:
 - a. Connect and Timeouts for the Tektronix printer driver.
 - b. Setup and Features for the Adobe PostScript driver.
3. Set the Timeout settings.

To change the timeout settings

Device Not Selected

Type a value from 0 to 999 to change the number of seconds that Windows waits before notifying you that a printer is off-line. The default is 15 seconds.

Transmission Retry

Type a value between 45 and 999; the default setting is 45 seconds.

On large or multiple-page documents you may see an Alert message that the printer is no longer accepting data before the job is completely sent to the printer. When using a shared printer, you should set this option to a larger value, such as 900 seconds (15 minutes) to avoid these unnecessary timeouts.

Printing from a Macintosh

To print from a Macintosh, you need a printer driver. Installing one of the supported drivers allows you to select printing features right from your computer. Refer to page 4-13 for a reference table of printing features and to page 4-20 for detailed information.

Supported Macintosh printer drivers

To select printer-specific features, print from one of the following provided drivers. See page 4-13 for a reference table listing the printing features, and how to find them quickly, in each of these drivers.

Phaser 560 driver	see page 4-15
Phaser 560 GX driver	see page 4-17
Apple LaserWriter 8 driver	see page 4-16

Using the printer's front panel

Without a supported driver, you can make some printing selections from the printer's front panel. Refer to page 4-21 for a list of front panel selections and to page 8-1 for instructions on using the front panel.

Downloading utility files

For information on selecting print options with utility files, refer to the online documents on the printer's CD-ROM or the Tektronix World Wide Web site.

Print features quick reference: Macintosh printer drivers

Feature	Page #	Driver name		
		Phaser 560	Apple LaserWriter 8	Phaser 560 GX
Media size <ul style="list-style-type: none"> ■ Letter * ■ Legal ■ A4 	page 4-30	Page Setup ↳ Paper	Page Setup ↳ Paper	Page Setup ↳ Paper
Tray selection <ul style="list-style-type: none"> ■ Paper * ■ Transparency ■ Upper Tray ■ Middle Tray † ■ Lower Tray † ■ Multi-Purpose Tray ■ Multi-Purpose Manual Feed 	page 4-33, page 4-35	Print ↳ TekColor Options ↳ Tray Selection	Print ↳ Paper Source	Printing ↳ Printer Driver Defaults ↳ Tray Selection
Multi-Purpose Manual Feed Media <ul style="list-style-type: none"> ■ Paper * ■ Paper 2nd Side ■ Transparency ■ Coated Paper ■ Card or Envelope ■ Label ■ Fabric Transfer 	page 4-33, page 4-40	Print ↳ TekColor Options ↳ MP Manual Feed Media	Print ↳ Options ↳ MP Manual Feed Media	Printing ↳ Printer Driver Defaults ↳ MP Manual Feed Media
Print quality modes <ul style="list-style-type: none"> ■ Fast Monochrome ■ Fast Color ■ Presentation ■ Standard * ■ Premium ‡ 	page 4-23	Print ↳ TekColor Options ↳ Print Quality	Print ↳ Options ↳ Print Quality	Printing ↳ Printer Driver Defaults ↳ Print Quality

* Factory default setting.

† Available only with the Lower Tray Assembly.

‡ Available only with the Extended Features option.

4 Printing Basics

Print features quick reference: Macintosh printer drivers (cont'd.)

Feature	Page #	Driver name		
		Phaser 560	Apple LaserWriter 8	Phaser 560 GX
Color correction <ul style="list-style-type: none"> ■ Automatic * ■ None ■ Vivid Color ■ Simulate Display ■ SWOP Press ■ Euroscale Press ■ Commercial Press ■ Use Printer Setting 	page 4-24	Print <ul style="list-style-type: none"> ↳ TekColor Options ↳ Color Correction 	Print <ul style="list-style-type: none"> ↳ Options ↳ Color Correction 	Printing <ul style="list-style-type: none"> ↳ Printer Driver Defaults ↳ Color Correction
Quick Collate † <ul style="list-style-type: none"> ■ On ■ Off * 	page 5-8	Print <ul style="list-style-type: none"> ↳ TekColor Options ↳ Quick Collate 	Print <ul style="list-style-type: none"> ↳ Options ↳ Quick Collate 	Printing <ul style="list-style-type: none"> ↳ Printer Driver Defaults ↳ Quick Collate
Check Print † <ul style="list-style-type: none"> ■ On ■ Off * 	page 5-11	Print <ul style="list-style-type: none"> ↳ TekColor Options ↳ Check Print 	Print <ul style="list-style-type: none"> ↳ Options ↳ Check Print 	Printing <ul style="list-style-type: none"> ↳ Printer Driver Defaults ↳ Check Print
Image Smoothing <ul style="list-style-type: none"> ■ On ■ Off * 	page 5-14	Print <ul style="list-style-type: none"> ↳ TekColor Options ↳ Image Smoothing 	Print <ul style="list-style-type: none"> ↳ Options ↳ Image Smoothing 	Printing <ul style="list-style-type: none"> ↳ Printer Driver Defaults ↳ Image Smoothing
Output Order <ul style="list-style-type: none"> ■ Face Up (on) * ■ Face Down (off) 	page 4-25	Print <ul style="list-style-type: none"> ↳ TekColor Options ↳ Output Face Up 	Print <ul style="list-style-type: none"> ↳ Options ↳ Output Order 	Printing <ul style="list-style-type: none"> ↳ Printer Driver Defaults ↳ Output Face Up

* Factory default setting.

† Available only with the Lower Tray Assembly.

‡ Available only with the Extended Features option.

Using the Phaser 560 printer driver

Select media size

1. From the File menu, open the Page Setup dialog box.
2. Use the Paper pop-up menu to select the printer's supported paper sizes.

Select printer-specific options

1. From the File menu, open the Print dialog box.
2. Click the TekColor button in the Print dialog box to see the TekColor Options dialog box.
3. Select printer-specific options:
 - Color Correction
 - Tray Selection *
 - MP Manual Feed Media *
 - Print Quality
 - Output Face Up
 - Check Print
 - Quick Collate
 - Image Smoothing

* Using the Multi-Purpose Feeder

In the TekColor Options dialog box, select one of the following under Tray Selection:

- Multi-Purpose Tray
Automatically selects the media type defined in the printer's front panel.
- Multi-Purpose Manual Feed
Allows you to select any of the following media types under MP Manual Feed Media:
 - Paper
 - Paper 2nd Side
 - Transparency
 - Coated Paper
 - Card or Envelope
 - Label
 - Fabric Transfer

Note *Duplex printing (Paper 2nd Side) is supported for laser bond paper. Using other media for double-sided printing can shorten component life.*

Using the Apple LaserWriter 8 printer driver

Select media size

1. From the File menu, open the Page Setup dialog box.
2. Use the Paper pop-up menu to select the printer's supported paper sizes.

Select printer-specific options

1. From the File menu, open the Print dialog box.
2. Select the media tray* by location or type in the Paper Source field.
3. Click the Options button to see the Print Options dialog box.
4. Select printer-specific options:
 - MP Manual Feed Media*
 - Color Correction
 - Print Quality
 - Image Smoothing
 - Output Face Up
 - Quick Collate
 - Check Print

* Using the Multi-Purpose Feeder

In the Print dialog box, select one of the following in the Paper Source field.

- Multi-Purpose Tray
Automatically selects the media type defined in the printer's front panel.
- Multi-Purpose Manual Feed
Allows you to select any of the following media types (to do this, select MP Manual Feed Media in the Print Options dialog box):
 - Paper
 - Paper 2nd Side
 - Transparency
 - Coated Paper
 - Card or Envelope
 - Label
 - Fabric Transfer

Note *Duplex printing (Paper 2nd Side) is supported for laser bond paper. Using other media for double-sided printing can shorten component life.*

Using the Phaser 560 GX printer driver

Note Refer to the on-line manuals on the printer's CD-ROM for details on using the Phaser 560 GX printer driver.

Printing with a desktop printer

If you are using QuickDraw GX applications, do *one* of the following:

- Select any desktop printer in the Print dialog box.
- Drag a document onto a desktop printer icon. The application corresponding to the document opens, prints the document, and then quits.

If you are using non-QuickDraw GX applications, do *one* of the following:

- Print to the *default* desktop printer with the Print command from the File menu.
- Drag a document onto a desktop printer icon. The application corresponding to the document opens, displays the Print dialog box, and waits for you to click Print. After printing the document, the application quits.

Selecting printing options

Most of the commands in the Printing menu are standard QuickDraw GX driver commands, and are documented by Apple (see the *Macintosh Guide* on-line document for details). The last group of commands in this menu are printer-specific.

Use the Printer Driver Defaults command in the Printing menu to set default options for the selected desktop printer.

Note The printer defaults dialog box is also available through the Print command in the File menu for QuickDraw GX applications.

Printing from a workstation

Overview

You can print from a UNIX or VMS workstation through Ethernet, Token Ring, parallel, or serial interfaces. Workstation users can print from any application that generates color PostScript, or directly from the screen with the PhaserPrint software.

For instructions and examples on creating print queues for your specific platform, see the Tektronix World Wide Web site:

`http://www.tek.com/Color_Printers`

Or, you can contact Technical Support at 1-800-835-6100.

To use the TekColor color corrections and other printer features, use one of the following methods:

- PhaserPrint™ for UNIX software functions like a printer driver for selecting printing options, and provides fast screen copy printing.
- The menus on the printer's front panel let you select printing options; refer to page 8-1 for instructions on using the front panel.
- Downloadable utility files let you select printing options; refer to the on-line manuals on the printer's CD-ROM for instructions.

UNIX workstations

For UNIX environments, Tektronix offers the optional PhaserPrint™ for UNIX software which offers driver-selectable printer options and provides fast, raster file and screen copy printing to Tektronix color printers.

PhaserPrint for UNIX software is available for these workstations:

Workstation	Operating System
Sun	SunOS 4.1.3, Solaris 2.X
SGI	IRIX 5.2, 5.3, 6.X
HP 9000 700/800	HPUX 9.0.5, 10.X
IBM RS/6000	AIX 3.2, 4.X
DECstation	Ultrix 4.0, 4.4
DEC Alpha	OSF/1 3.0 and 3.2

PhaserPrint for UNIX software works with the workstation's native spooling system to print PostScript files and convert raster files to PostScript from these formats:

Sun Raster Format (SRF)	BMP (Microsoft Windows)
xwd	PCX (Paintbrush)
SGI RGB	PBM (Portable Bitmap)
HP Starbase	TIFF baseline with these extensions: <ul style="list-style-type: none"> ■ CCITT Bi-level Encoding ■ LZW compression ■ Pack Bits compression ■ JPEG compression

The printer's CD-ROM contains a demonstration copy of PhaserPrint for UNIX software and an on-line instruction guide in the *UNIX/UNIXDEMO* directory. If you would like to purchase a licensed version of PhaserPrint software, contact your dealer, local Tektronix office, or in the United States, call 1-800-835-6100.

For more information

- **World Wide Web:** If you have access to the Internet, you can view selected topics on the Phaser 560 printer's web page. Access the printer's documentation from this web address:

http://www.tek.com/Color_Printers/userdoc/introduction.html

- **HAL:** Request a document catalog from HAL or EuroHAL, Tektronix' automated fax systems. Refer to "Using the automated fax systems" on page 7-3 for instructions on using HAL and EuroHAL.

Printing from specific applications

For printing from most applications, follow the instructions in “Installing Printer Software” on page 3-1 to install drivers and printer software. Some applications require additional configuration or page description files, which may have been installed with the driver.

General hints and tips

For printing hints and tips beyond the information provided in the application’s manuals, look for additional information in the following places:

- **World Wide Web:** If you have access to the Internet, you can view selected topics on the Phaser 560 printer’s web page. Access the printer’s documentation from this web address:

http://www.tek.com/Color_Printers/userdoc/introduction.html

- **HAL:** Request a document catalog from HAL or EuroHAL, Tektronix’ automated fax systems. Refer to “Using the automated fax systems” on page 7-3 for instructions on using HAL and EuroHAL.

Print features

This printer provides several ways to select print features:

- **Through a supported printer driver (recommended)**
Use these selections to override the settings selected from the printer’s front panel.
- **From the printer’s front panel**
Use these settings when printing from a non-supported driver (one that does not support the printer’s features).
- **Using PhaserLink software**
If your network is running TCP/IP and you have a World Wide Web browser, you can use this browser to view printer status and select printer features. Refer to the *PhaserShare Status Software User Manual* for complete information.
- **Sending a PostScript utility file to the printer**
Use these settings *only* when printing from a non-supported driver. You can find detailed information on the printer’s CD-ROM and the Tektronix web page:

http://www.tek.com/Color_Printers/userdoc/introduction.html

This table provides an overview of selecting print features in the printer's front panel.

Print features quick reference: Printer's front panel

Feature	Feature descriptions	Front Panel
Print-Quality Modes <ul style="list-style-type: none"> ■ Fast Monochrome ■ Fast Color ■ Presentation ■ Standard* ■ Premium† 	See page 4-23	Printer Defaults Menu ↳ Print Quality Menu
Color Correction <ul style="list-style-type: none"> ■ Automatic* ■ None ■ Vivid Color ■ Display ■ SWOP Press ■ Euroscale Press ■ Commercial Press 	See page 4-24	Printer Defaults Menu ↳ TekColor Correction Menu
Default Tray <ul style="list-style-type: none"> ■ Multi-Purpose ■ Media Tray ■ Upper* ■ Middle† ■ Lower‡ ■ Paper ■ Transparency ■ Auto Select 	See page 4-33	Printer Defaults Menu ↳ Default Tray Menu
Media Size <ul style="list-style-type: none"> ■ Letter* ■ Legal ■ A4 	See page 4-30	Media Defaults Menu ↳ Multi-Purpose Feeder ↳ Media Size Menu
Multi-Purpose Media Type <ul style="list-style-type: none"> ■ Paper* ■ Paper 2nd Side ■ Transparency ■ Coated Paper ■ Card or Envelope ■ Label ■ Fabric Transfer 	See page 4-33	Media Defaults Menu ↳ Multi-Purpose Feeder ↳ Media Type Menu

* Factory default setting.
† Available with the Lower Tray Assembly.
‡ Available with the Extended Features option.

Print features quick reference: Printer's front panel (cont'd.)

Feature	Feature descriptions	Front Panel
Startup Page <ul style="list-style-type: none"> ■ Enabled* ■ Disabled 	See page 8-10	Printer Defaults Menu ↳ Startup Page Menu
Startup Mode <ul style="list-style-type: none"> ■ Enabled* ■ Disabled 	See the topic on the printer's CD-ROM	Printer Defaults Menu ↳ Startup Mode Menu
Output Order <ul style="list-style-type: none"> ■ Face Up* ■ Face Down 	See page 4-25	Printer Defaults Menu ↳ Output Order Menu
Error Handler <ul style="list-style-type: none"> ■ Enabled ■ Disabled* 	See page 7-27	Printer Defaults Menu ↳ PS Error Handler Menu
Image Smoothing <ul style="list-style-type: none"> ■ Default Smoothing* ■ Smooth All Images 	See page 5-14	Printer Defaults Menu ↳ Image Smoothing Menu
Energy Star <ul style="list-style-type: none"> ■ Enabled* ■ Disabled 	See page 2-24	Printer Defaults Menu ↳ Energy Star Menu
Energy Star Timeout <ul style="list-style-type: none"> ■ 1 Hr. 	See page 2-24	Printer Defaults Menu ↳ Energy Star Timeout Menu
Check Print † <ul style="list-style-type: none"> ■ Enabled ■ Disabled* 	See page 5-11	Printer Defaults Menu ↳ Check Print Menu
Check Print Timeout <ul style="list-style-type: none"> ■ 5 Min. 		Printer Defaults Menu ↳ Check Print Timeout Menu

* Factory default setting.

† Available with the Lower Tray Assembly.

‡ Available with the Extended Features option.

Print-quality modes

Mode	Resolution (dots per inch)	Printing speed (pages per minute)	Description
Fast Monochrome	600 x 600 dpi	14 ppm	<ul style="list-style-type: none"> ■ Fastest grayscale printing. ■ Recommended for documents containing large amounts of black text.
Fast Color	600 x 600 dpi	5 ppm	<ul style="list-style-type: none"> ■ Fastest full-color output. ■ When printing raster image data or color graphics, this mode provides excellent output using CMY toners. ■ Not recommended for documents containing large amounts of black text.
Presentation	600 x 600 dpi	Color 4 ppm Monochrome 14 ppm	<ul style="list-style-type: none"> ■ Smoothest and brightest large-area fills. ■ Useful for printing paper copies of overhead presentations.
Standard	600 x 600 dpi	Color 4 ppm Monochrome 14 ppm	<ul style="list-style-type: none"> ■ General-purpose mode for full-color printing.
Premium	1200 x 1200 dpi	Color 2 ppm Monochrome 7 ppm	<ul style="list-style-type: none"> ■ Requires the Extended Features option (including a minimum of 24 Mbytes of memory). ■ Highest quality color prints. ■ Near-photographic detail. ■ If you select Premium mode but the printer does not have the Extended Features option and sufficient memory installed, prints are made in Standard mode.

Note *For all of the print modes, you can get faster overall throughput when more memory is installed.*

Color corrections

The printer provides TekColor Dynamic Correction, which consists of the following color correction modes:

Color correction mode		Description
Front panel selection	Driver selection	
Automatic	Automatic	Default setting. Automatically selects the optimum color correction for speed, vividness, and saturation. Text and filled areas use Vivid Color on opaque media. RGB bit-mapped images use Simulate Display . CMYK bit-mapped images use Commercial Press .
None	None	No correction made to colors.
Vivid Color	Vivid Color	Produces the brightest possible colors.
Display	Simulate Display	Adjusts color to closely approximate the colors on a standard display screen.
SWOP	SWOP Press	Specification for Web Offset Publications. Typically used to match U.S. press standards.
Euroscale	Euroscale Press	Used to match equivalent 3M Matchprint [®] proofs.
Commercial	Commercial Press	Used to match commercial 3M Matchprint [®] proofs.
n/a	Use Printer Setting	Uses the color correction mode specified in the printer's front panel setting rather than any printer driver setting.
Monochrome*	n/a	Leaves gray as is; converts RGB and CMYK to pure gray.
Raw RGB*	n/a	Leaves RGB as is; converts CMYK and gray to RGB.
Raw CMYK*	n/a	Leaves CMYK as is; converts RGB and gray to CMYK.

* Available only with a downloadable utility file.

You can view sample output of four of the color correction modes at the bottom of the Startup Page. Refer to page 8-8 for instructions on printing the Startup Page.

Note *If your printer is on a network and you have changed the front panel settings, make sure that you tell other users on the network. The front panel printer settings affect all prints made with non-Tektronix drivers.*

Output Order

This option lets you specify whether your document prints face up or face down in the printer's output tray. You can select it either in one of the supported drivers (Output Order option, Output Face Up option) or in the printer's front panel (Output Order in the Printer Defaults menu).

Output Order: Face Up

- Pages are output so that the *first* page is on the bottom.
- **Driver selection**
Check the Output Face Up box on, or select Face Up, depending on the driver you are using.

Output Order: Face Down

- Pages are output *face down in numerical order*.
- **Driver selection**
Uncheck the Output Face Up box, or select Face Down depending on the driver you are using.

Hints

- ▼ When printing on transparencies, the printer always prints your document *face up*.
- ▼ If you are using the Quick Collate option, make sure you select Output Face Down, or uncheck the Output Face Up box, depending on the driver you are using.
- ▼ Output order for prints from the Multi-Purpose Feeder is always *face up*.

Fonts

Note *For general information on fonts, request a document catalog from HAL or EuroHAL, the Tektronix automated fax systems. Refer to page 7-3 for information on using these systems.*

Resident typefaces (PostScript)

The printer accepts Adobe Type 1 and Type 3 downloadable fonts, TrueType fonts, PCL5, and a variety of user-defined fonts. To extend font capability, the printer supports a SCSI-connected external hard disk for storage of additional fonts. Refer to the topics on the printer's CD-ROM or on the Tektronix World Wide Web site for more information.

The printer's standard configuration is shipped with a set of 17 resident fonts.

Courier
Courier Bold
Courier Oblique
Courier Bold Oblique

Helvetica
Helvetica Bold
Helvetica Oblique
Helvetica Bold Oblique

Helvetica Narrow
Helvetica Narrow Bold
Helvetica Narrow Oblique
Helvetica Narrow Bold Oblique

Times Roman
Times Bold
Times Italic
Times Bold Italic

Symbol (Σ ψ μ β ο λ)

9480-59

Additional fonts can be added to a Phaser 560 printer. The Extended Features option includes these 39 fonts. Refer to “Upgrade kits” on page 9-5 for ordering information.

Courier

Courier Bold

Courier Oblique

Courier Bold Oblique

ITC Avant Garde Gothic Book

ITC Avant Garde Gothic Book Oblique

ITC Avant Garde Gothic Demi

ITC Avant Garde Gothic Demi Oblique

ITC Bookman Light

ITC Bookman Light Italic

ITC Bookman Demi

ITC Bookman Demi Italic

Helvetica

Helvetica Bold

Helvetica Oblique

Helvetica Bold Oblique

Helvetica Condensed

Helvetica Condensed Bold

Helvetica Condensed Oblique

Helvetica Condensed Bold Oblique

Helvetica Narrow

Helvetica Narrow Bold

Helvetica Narrow Oblique

Helvetica Narrow Bold Oblique

New Century Schoolbook

New Century Schoolbook Bold

New Century Schoolbook Italic

New Century Schoolbook Bold Italic

Palatino

Palatino Italic

Palatino Bold

Palatino Bold Italic

Times Roman

Times Bold

Times Italic

Times Bold Italic

ITC Zapf Chancery Medium Italic

☆*⋄⊗⊕⊖⊗⊘⊙⊚⊛⊜⊝⊞⊟⊠⊡⊢⊣⊤⊥⊦⊧⊨⊩⊪⊫⊬⊭⊮⊯⊰⊱⊲⊳⊴⊵⊶⊷⊸⊹⊺⊻⊼⊽⊾⊿ (ITC Zapf Dingbats)

Σψμβoλ (Symbol)

9317-10

Resident typefaces (PCL5)

For PCL5 (Printer Command Language) printing (HP Laserjet III emulation), the printer supports Courier, Times, and Universe typefaces in medium, bold, italic medium, and italic bold.

Downloading fonts

The printer accepts PostScript Type 1, Type 3, and TrueType downloadable fonts.

If you have an external hard disk connected to a Phaser 560 printer, you can store the downloadable fonts on it. You can use utilities on the CD-ROM to download fonts to the printer. For details, refer to the topics on the printer's CD-ROM or on the Tektronix World Wide Web site.

Macintosh fonts

The Macintosh Driver and Printer Utilities diskette and CD-ROM include screen fonts for these typeface families: Times, Helvetica, Courier, Symbol, Helvetica Condensed, Helvetica Narrow, Palatino, ITC Avant Garde Gothic, ITC Bookman, ITC Zapf Chancery, ITC Zapf Dingbats, and New Century Schoolbook.

If they are not already installed, you must install these screen fonts to see the printer's resident typefaces on the Macintosh screen. Refer to the topics on the printer's CD-ROM or on the Tektronix World Wide Web site for details.

Printer languages: PostScript, HP-GL, PCL5

The printer supports PostScript Level 1 and Level 2 and HP-GL (Hewlett-Packard Graphics Language) printer languages. Additionally, the printer supports monochrome PCL5 (Printer Command Language). Refer to the topics on the printer's CD-ROM or the Tektronix World Wide Web page for details.

The default language for the parallel port is PostScript. For information on default language for other interface ports, refer to the *PhaserShare Network Cards and Software System Administrator User Manual*.

If you want to print HP-GL or PCL5 files on a port set to PostScript, you must set up that printer port for that type of data or enable Adobe IntelliSelect™ automatic language selection. Refer to the topics on the printer's CD-ROM or the Tektronix World Wide Web page for instructions.

If automatic language selection is enabled, you can send PostScript, HP-GL, and PCL5 files to the printer and the printer automatically detects the type of file and prints it. You can change the default language so that the next time you turn on the printer, it is set to receive PostScript, HP-GL, or PCL5 data on a specific port.

The printer has default values for the HP-GL parameters, such as pen color and pen width. However, you can change these values. Refer to the topics on the printer's CD-ROM or the Tektronix World Wide Web page for instructions.

All about media

Media sizes

This printer supports three sizes of media trays:

Size		Media Type	
		Paper	Transparency
A/Letter	8.5 x 11 in.	✓	✓
A4	210 x 297 mm	✓	✓
Legal	8.5 x 14 in. 216 x 356 mm	✓	

In addition to using the media trays, you can load specialty media in the Multi-Purpose Feeder, which accommodates media ranging in size from 89 x 254 mm to 216 x 356 mm (3.5 x 10 in. to 8.5 x 14 in.). For more information on specialty media, refer to “Using the Multi-Purpose Feeder” on page 4-40 and “Loading specialty media in the Multi-Purpose Feeder” on page 4-44.

Margins and print area

When the printer places an image on media, the image (print area) is a bit smaller than the media size. You may need to adjust the page margins in your application software to match the print area.

Note *To assure the correct page margins, use the drivers supplied on the printer's CD-ROM and diskettes.*

The following table and illustration show the page sizes, the largest print areas, and the margins for the media sizes supported on this printer.

Media	Page size	Print area	Margins		
			Top	Bottom	Sides
1. Letter	8.5 x 11 in.	8.2 x 10.6 in.	.2 in.	.2 in.	.15 in.
2. A4	210 x 297 mm	200 x 288 mm	5 mm	5 mm	5 mm
3. Legal	8.5 x 14 in.	8.2 x 13.5 in.	.2 in.	.2 in.	.15 in.

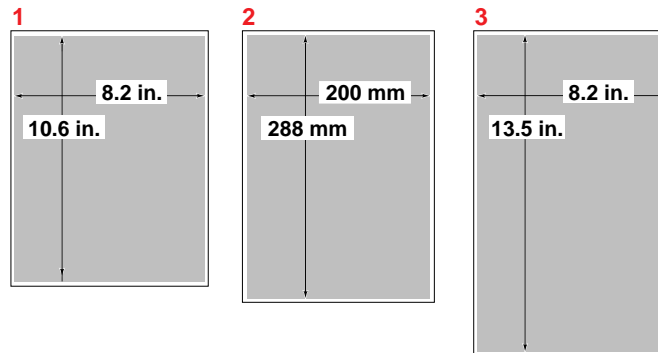

9698-86

Media types

This printer accommodates several types of media in various sizes. Paper and transparencies can be loaded in either the Multi-Purpose Feeder or any of the media trays.

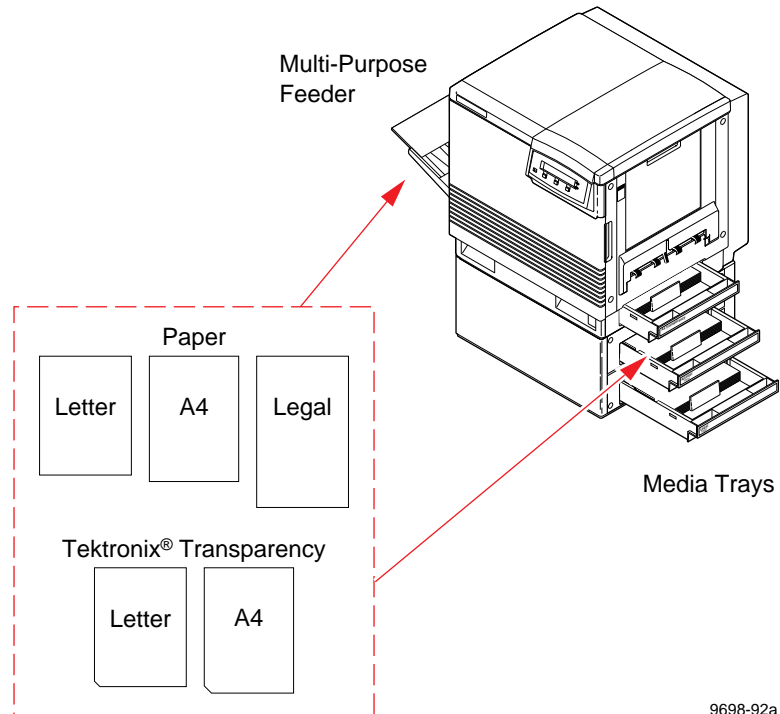

9698-92a

Caution *Do not use any media designed for inkjet printers, especially inkjet coated paper and inkjet transparencies. Inkjet media are coated with a substance that will damage the fuser; Tektronix does not furnish service for damage or malfunction caused by the use of non-Tektronix supplies or consumables. Always use Tektronix-brand coated paper and transparencies that have been specially designed for use with Tektronix Color Laser Printers.*

Specialty media can *only* be printed from the Multi-Purpose Feeder.

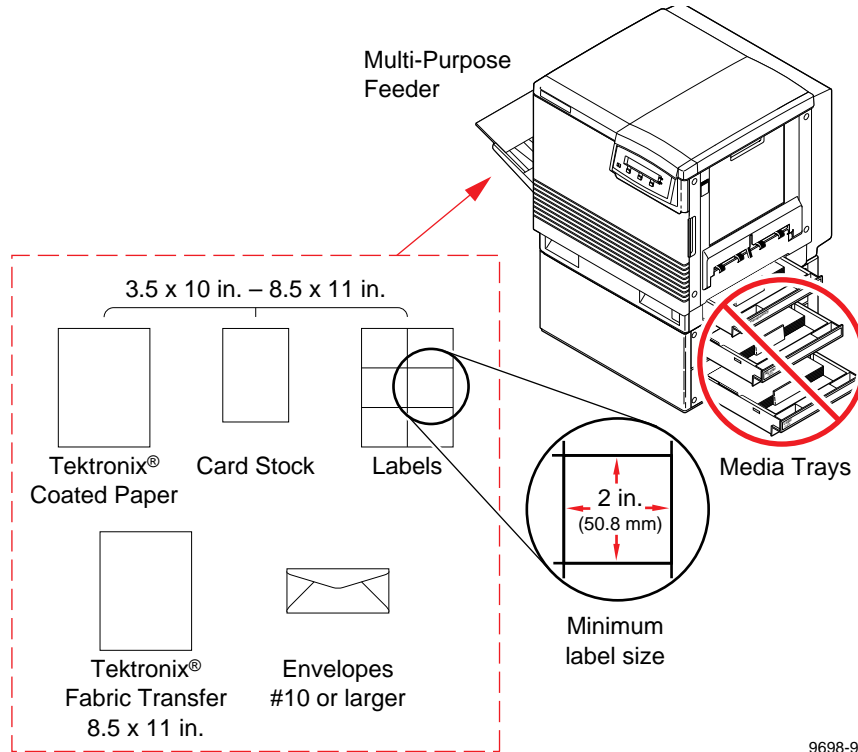

Selecting a media type

You can select a media *type* in the printer's front panel or in a supported printer driver.

Media trays

The printer is shipped with a PAPER tray, either Letter Paper (U.S.) or A4 Paper (Metric), depending on the order option. Optional trays (either Letter Transparency, A4 Transparency, or Legal Paper) are also available:

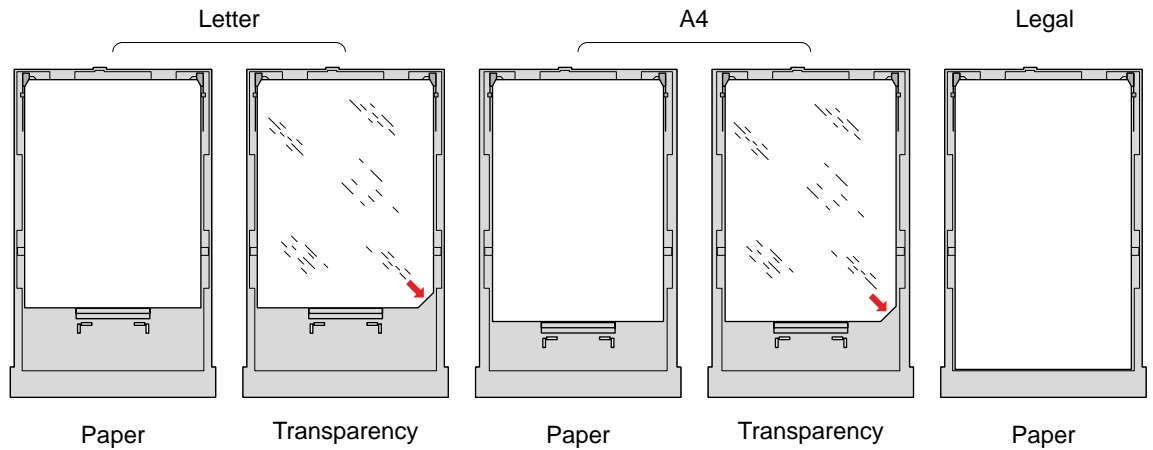

9698-94

Hints

- ▼ For the best print quality, load only paper in the PAPER tray and transparencies in the TRANSPARENCY tray.
- ▼ If you have the Lower Tray Assembly installed, insert the TRANSPARENCY tray only into the upper (A) or middle (B) tray slots for the most reliable media-picking.
- ▼ When printing a large number of sheets of paper or transparency, use the media-specific trays for best reliability.
- ▼ When using specialty media, always use the Multi-Purpose Feeder (D).

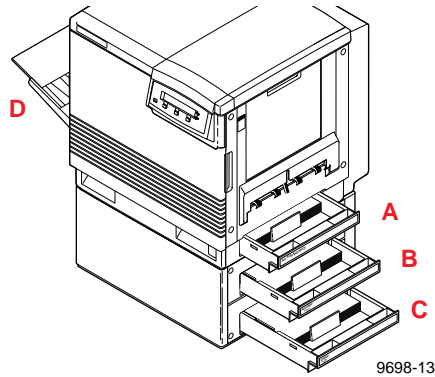

Selecting a media tray by location

When you select a media tray by *location*, the printer picks media from that tray, regardless of the tray's media type or size.

Loading plain paper

1. Push down on the PAPER tray's metal plate until it clicks, locking it in place.

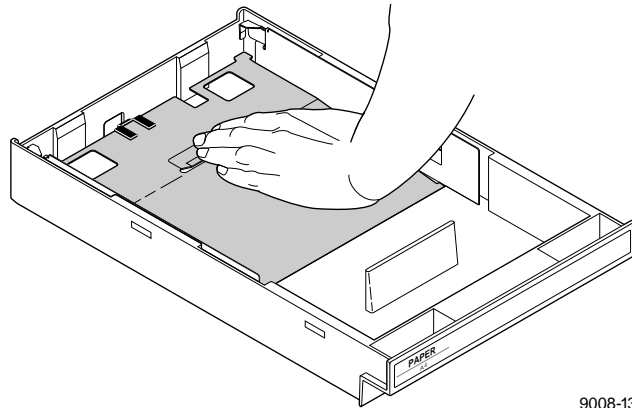

9008-13

2. Fan the paper, but be careful not to leave fingerprints, which can result in a smudged print.
3. Place paper in the tray under the hooks.
4. You can load approximately 250 sheets of paper, depending on the thickness. Use the label on the inside of the tray as a reference for the proper amount of media.

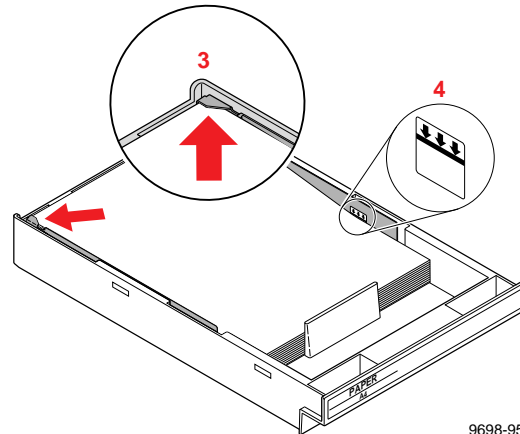

9698-95

5. Insert the PAPER tray into any of the three tray slots on the printer.

Loading letterhead paper

1. Push down on the PAPER tray's metal plate until it clicks, locking it in place.

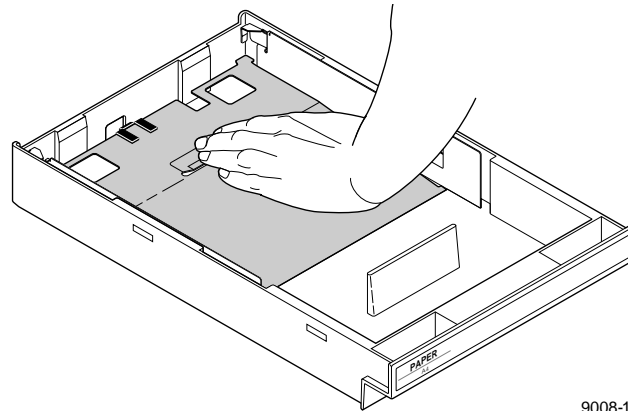

9008-13

2. Fan the letterhead paper, but be careful not to leave fingerprints, which can result in a smudged print.
3. Load the letterhead paper in the tray so that the side to be printed is *face down* and the top of the page is placed under the hooks.
4. You can load up to 250 sheets of paper, depending on its thickness. Use the label on the inside of the tray as a reference for the proper amount of media.

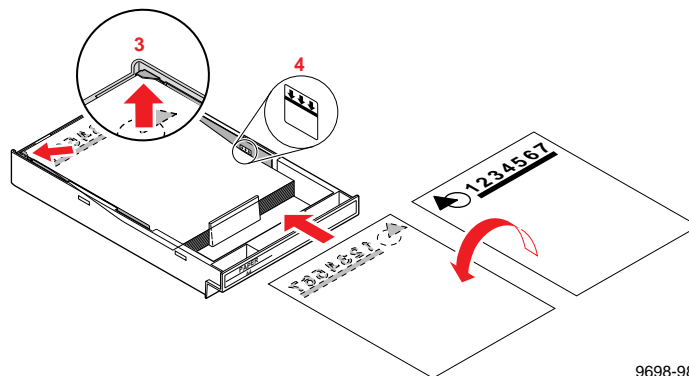

9698-98

5. Insert the PAPER tray into any of the three slots on the printer.

Loading transparencies

1. Push down on the TRANSPARENCY tray's metal plate until it clicks, locking it in place.

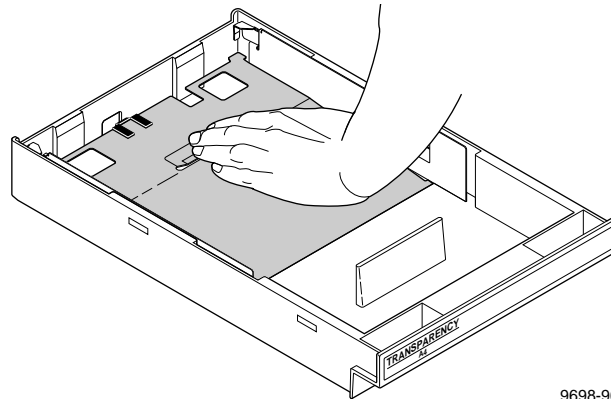

9698-96

2. Fan the transparencies, but be careful not to leave fingerprints, which can result in a smudged print.
3. Place transparencies in the tray under the hooks.
4. Load the transparencies so that the notched corner is placed closest to the media level label (5).
5. You can load approximately 100 sheets of transparency film. Use the label on the inside of the tray as a reference for the proper amount of media.
6. Insert the TRANSPARENCY tray into the Upper or Middle trays slot on the printer.

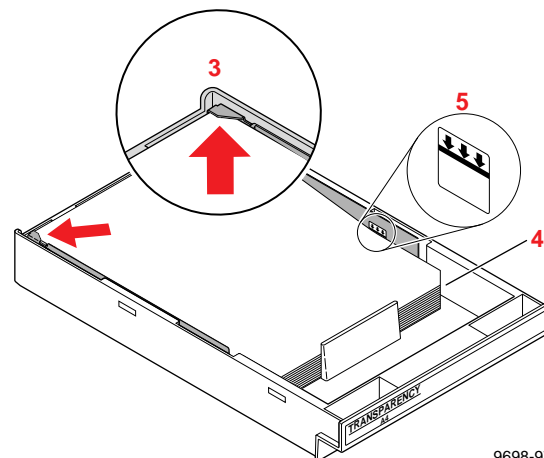

9698-97

Hints for making transparencies

Follow these guidelines when you make transparencies:

- ▼ Use *only* Tektronix transparencies.
- ▼ For the best printing reliability, use the TRANSPARENCY tray for printing multiple sheets of transparency.
- ▼ When using the Multi-Purpose Feeder to print transparencies (page 4-44), make sure that you select Transparency in either the front panel or a printer driver for the best print quality; make sure that you set the Media Thickness switch to Medium for the best media-picking reliability.

Caution *Do not use any media designed for inkjet printers, especially inkjet coated paper and inkjet transparencies. Inkjet media are coated with a substance that will damage the fuser; Tektronix does not furnish service for damage or malfunction caused by the use of non-Tektronix supplies or consumables. Always use Tektronix-brand coated paper and transparencies that have been specially designed for use with Tektronix Color Laser Printers.*

Using the Multi-Purpose Feeder

The Multi-Purpose Feeder serves as another tray for loading any type of media that ranges in size from 89 x 254 mm to 216 x 356 mm (3.5 x 10 in. to 8.5 x 14 in.). You can use it to load a single sheet or a stack of media, depending on the media's type and thickness.

Use the Multi-Purpose Feeder to accomplish the following:

- Print on standard and specialty media

Standard media

- Laser paper
- Transparencies

Specialty media

- Glossy coated paper
- Card stock
- Labels
- Fabric transfer
- Envelopes (#10 size or larger)

Note *For detailed information on loading specialty media and setting the appropriate media thickness, refer to “Loading specialty media in the Multi-Purpose Feeder” on page 4-44.*

- Duplex printing (double-sided) on laser paper

Caution *Use laser bond paper for duplexing; two-sided printing on specialty media can shorten component life. For opacity and feed reliability, use paper that is at least 100 g/m² (28 lb. bond). For best results, do not use heavy toner coverage on Side 1.*

Setting media thickness

Because the printer accommodates varying media weights in the Multi-Purpose Feeder, you can manually select a media thickness for the most reliable paper-picking. The Media Thickness switch is only applicable for the Multi-Purpose Feeder.

Follow these steps to adjust the media thickness:

1. Open the left side door. The blue Media Thickness switch is located on the paper feeder and has three settings:
 - a. Thin
 - b. Medium
 - c. Thick

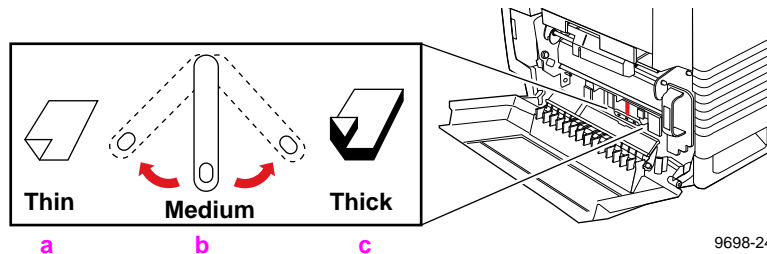

9698-24

2. Move the switch to the setting for the desired media. Use the guidelines in the following table to determine which type of media requires which setting.

Thin	Medium	Thick
Laser paper 75 - 105 g/m ² (20 - 28 lb.)	Laser paper* 109 - 150 g/m ² (29 - 39 lb.)	Cover stock up to 176 g/m ² (65 lb.)
	Tektronix Glossy coated paper	Card stock / Index up to 165 g/m ² (90 lb.)
	Tektronix Transparencies	Tektronix Fabric Transfer Media
		Labels
		Envelopes

* For the best coverage when using heavy laser paper (over 105 g/m², 28 lb.) in the Multi-Purpose Feeder, select **Card** as the media type.

Note *If you experience frequent paper jams at the Multi-Purpose Feeder, move the media thickness switch to a thicker setting. If you experience frequent double-feed errors at the Multi-Purpose Feeder, move the media thickness switch to a thinner setting.*

Inserting the media

For instructions on loading specific types of media, refer to “Loading specialty media in the Multi-Purpose Feeder” on page 4-44.

1. Adjust the guides to the width of the media you are using.

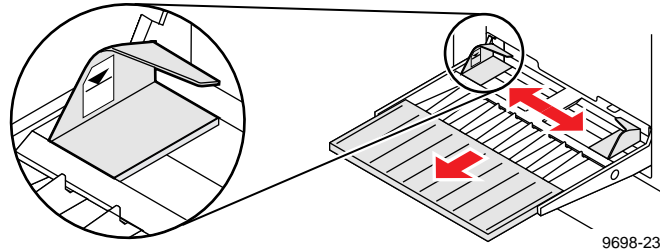

2. Insert the media with the side to be printed *up* and the top of the page entering the printer *first*.
3. Take care not to overfill the Multi-Purpose Feeder: keep the media to just below the limit indicator.

Capacity in the Multi-Purpose Feeder varies, depending on media thickness. These are general guidelines:

■ Laser paper	100 sheets
■ Transparencies	50 sheets
■ Glossy coated paper	75 sheets
■ Card stock	30 sheets
■ Label stock	30 sheets
■ Fabric transfer	1 sheet
■ Envelopes	10 envelopes

4. Select the Multi-Purpose Feeder in the printer driver or the printer’s front panel (refer to the next topic).

Selecting the Multi-Purpose Feeder

Select the Multi-Purpose Feeder in one of these two ways:

■ Driver selection

1. In the Print dialog box (under Tray Selection or Paper Source, depending on the driver), select one of the following:
 - Multi-Purpose Tray (automatically selects the media type defined in the front panel).
 - Multi-Purpose Manual Feed (see Step 2).
2. If you selected Multi-Purpose Manual Feed, select the media type or Paper 2nd Side in the MP Manual Feed Media pull-down menu (in the Options or TekColor Options dialog box, depending on the driver).

The printer waits 8 minutes for you to load the media and confirm your selection in the front panel before it cancels the job.

■ Front panel selection

1. Enter the front panel menu (press **Menu**) and navigate (press the right or left arrow button) to the **Printer Defaults** menu.
2. Select **Media Type** in the **Multi-Purpose Feeder** menu.
3. In the **Media Type** menu, select the desired media or **Paper 2nd Side** for double-sided printing.

The front panel setting is overridden by the driver selection for Multi-Purpose Manual Feed.

4. Press the **Exit** button to return to the **Multi-Purpose Feeder** menu.
5. Select **Media Size** in the **Multi-Purpose Feeder** menu.
6. In the **Media Size** menu, select the desired size media.

Loading specialty media in the Multi-Purpose Feeder

Transparencies

1. Set the Media Thickness switch to Medium.

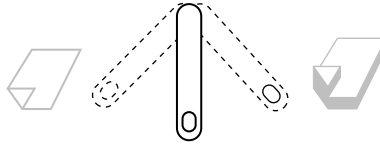

2. Adjust the guides for the width of your transparencies.
3. Insert the side with the notched end into the printer *last*, with the notched corner closest to the back of the printer.
4. Fill the Multi-Purpose Feeder to the level indicator on the guide (maximum capacity is 50 sheets).

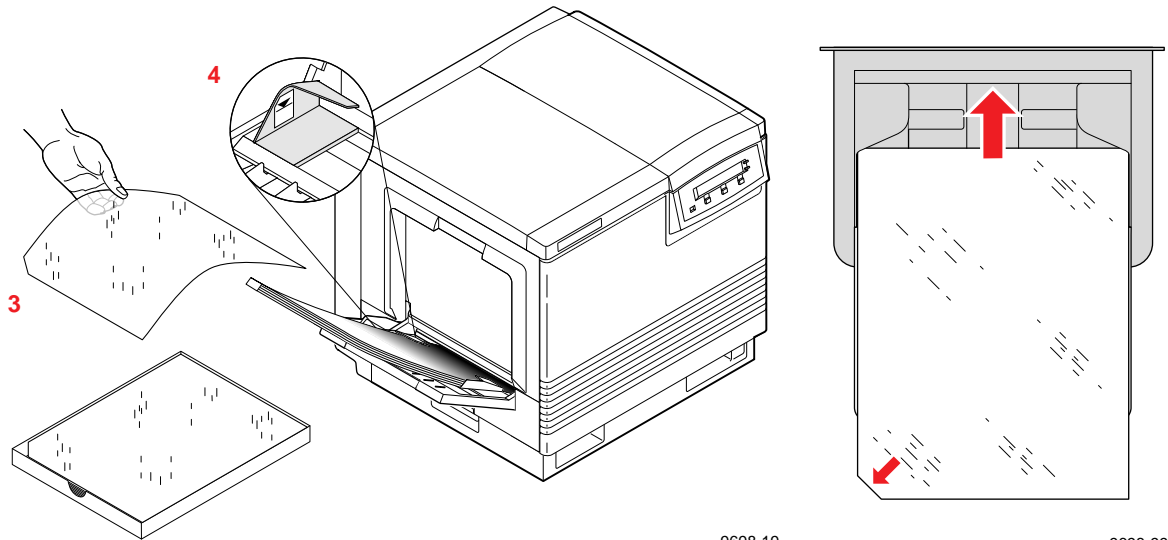

9698-19

9698-99

5. Use your printer driver or the front panel menu to select the Multi-Purpose Feeder and the media type (Transparency).

Letterhead

1. For the thickness setting, treat letterhead media as you would laser paper. If your letterhead paper has a weight of 105 g/m^2 (28 lb.) or lighter, adjust the printer's Media Thickness switch to Thin; if its weight is $109 - 150 \text{ g/m}^2$ (29 - 40 lb.), adjust the printer's Media Thickness switch to Medium; if its weight is heavier than 150 g/m^2 (40 lb.), adjust the printer's Media Thickness switch to Thick.

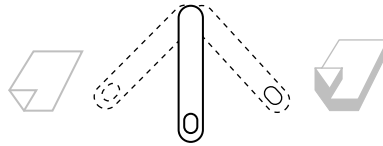

2. Adjust the media guides for the width of your paper.
3. Insert the letterhead paper with the side to be printed *up*; the top of the page enters the printer *first*.
4. Fill the Multi-Purpose Feeder up to the level indicator on the guide (maximum capacity is 100 sheets, depending on the media's thickness).

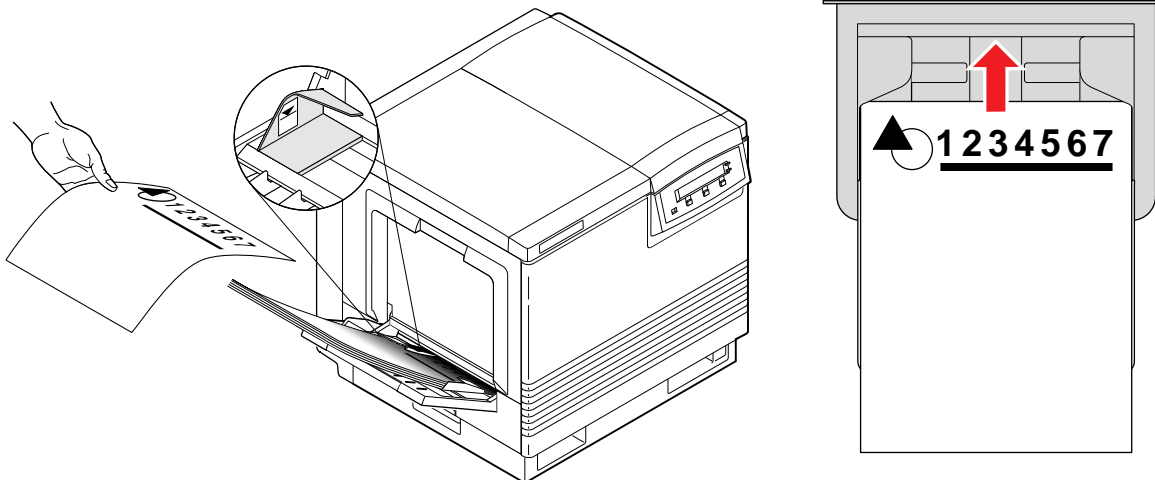

9698-100

5. Use your printer driver or the front panel menu to select the Multi-Purpose Feeder and the media type (Paper).

Glossy Coated Paper and Card stock

Caution *Do not use any media designed for inkjet printers, especially inkjet coated paper and inkjet transparencies. Inkjet media are coated with a substance that will damage the fuser; Tektronix does not furnish service for damage or malfunction caused by the use of non-Tektronix supplies or consumables. Always use Tektronix-brand coated paper and transparencies that have been specially designed for use with Tektronix Color Laser Printers.*

1. Adjust the printer's Media Thickness switch: Medium for Glossy Coated Paper and Thick for Card Stock.



2. Adjust the media guides for the width of your media.
3. Insert the media with the side to be printed *up* and the top entering the printer first.

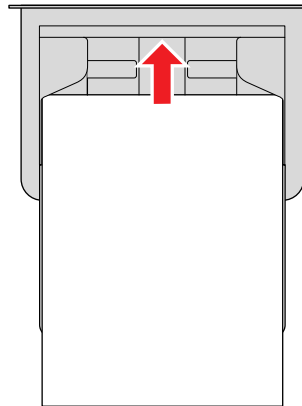

9698-116

4. Fill the Multi-Purpose Feeder up to the level indicator on the guide (maximum capacity is 50 sheets).
5. Use your printer driver or the front panel menu to select the Multi-Purpose Feeder and the media type (either Coated Paper or Card or Envelope).
6. If the media is a non-standard size, you must position the image correctly in the application.
 - a. Select a printer page size that is larger than your media.
 - b. Center the image of your media at the *top center* of the selected size in your application.

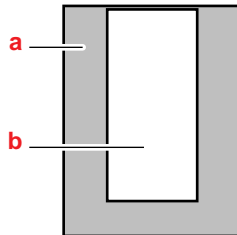

9698-117

Caution *To avoid media jams and damage to the printer components, make sure that you follow these guidelines:*

- *Use only Tektronix Glossy Coated paper.*
- *Do not print on the media's second side; only laser paper should be used for duplex printing.*

Envelopes

1. Prepare each envelope in the following manner:
 - Tri-fold a letter-sized piece of paper and insert it into the envelope.
 - Tuck the envelope flap inside the envelope.
2. Adjust the printer's Media Thickness switch to Thick.

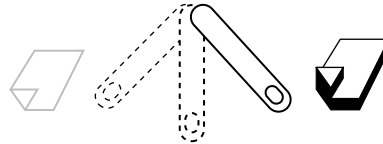

3. Adjust the printer's media guides for the width of your envelopes.
4. Insert the envelopes with the short end entering the printer *first* and the side to be printed facing *up*; the edge where you place the stamp enters the printer *first*.

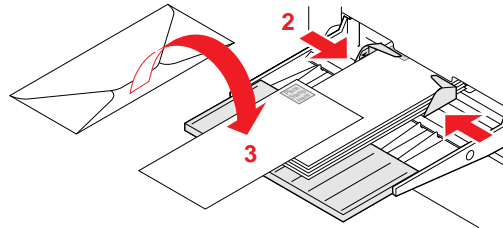

9698-44b

5. Fill the Multi-Purpose Feeder up to the level indicator on the guide (maximum capacity is 10-15 envelopes, depending on thickness).
6. **In your application.**
 - Create a document with the following measurements.:
 - Width 4.13 in. (104.1 mm)
 - Length 9.5 in. (241,3 mm)
 - Margins .25 in.
 - Access the Page Setup menu and set the orientation to Landscape.

7. In a supported printer driver.

Make the following selections.:

- | | |
|----------------|----------------------|
| ■ Paper Size | Letter |
| ■ Orientation | Portrait |
| ■ Paper Source | Multi-Purpose Feeder |
| ■ Media Type | Card or Envelope |

8. Send the job to the printer.**Hints**

- ▼ Many applications include a tool for creating an envelope document. For example, Microsoft Word includes an Envelopes and Labels feature under the Tools menu. Make sure that you select Face Up; select the feed method icon showing the stamp end entering the printer first, with the image centered; and unselect Clockwise Rotation.
- ▼ Check the printer's web site for any application- or platform-specific information for printing envelopes on the Phaser 560 printer.

Caution *To avoid media jams and damage to the printer components, make sure that you follow these guidelines:*

- *Use envelopes that are at least #10 size (104.1 x 241.3 mm / 4.1 x 9.5 in.) or larger.*
- *Do not use envelopes with a plastic window.*
- *Do not use envelopes with a metal clip.*
- *Make sure that the envelope has no exposed gummed surfaces; make sure that the gummed flap is closed and tucked into the envelope when inserting the envelope into the Multi-Purpose Feeder.*
- *Do not print on the envelope's second side; only laser paper should be used for duplex printing.*

Labels

1. Adjust the Media Thickness switch to Thick.

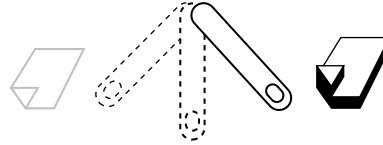

2. Adjust the media guides for the width of your label sheets.
3. Insert the label sheets with the side to be printed *up*, with the top of the sheet entering the printing *first*.

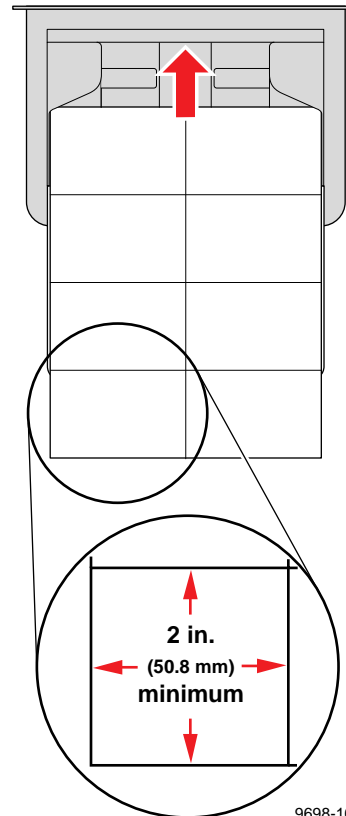

9698-101

4. Fill the Multi-Purpose Feeder to the level indicator on the guide (maximum capacity is 30 label sheets).
5. Use your printer driver or the front panel menu to select the Multi-Purpose Feeder and the media type (Label).

Caution *To avoid media jams and damage to the printer components, make sure that you follow these guidelines:*

- *The label sheets that you use must not have paper “frames” around each label; when the labels are removed from the backing, the backing has no paper remaining.*
- *Each label is at least 50.8 x 50.8 mm (2 x 2 in.) in size. Smaller labels may peel off and damage the fuser or imaging unit.*
- *If any of the labels on a sheet are missing, do not use that sheet; it may damage the fuser or imaging unit.*
- *When selecting Labels as the media type, the printer requires that the room temperature be cooler than 27° C (81° F). If the temperature is above 27° C (81° F), the printer reports an error and stops printing.*

Tektronix Fabric Transfer Media

1. Set the Media Thickness switch to Thick.

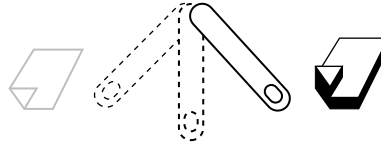

2. Adjust the media guides for the width of your Fabric Transfer media.
3. Insert *only* one sheet of media at a time, with the side to be printed *up* (logo side *down*) and the top of the media entering the printer *first*.

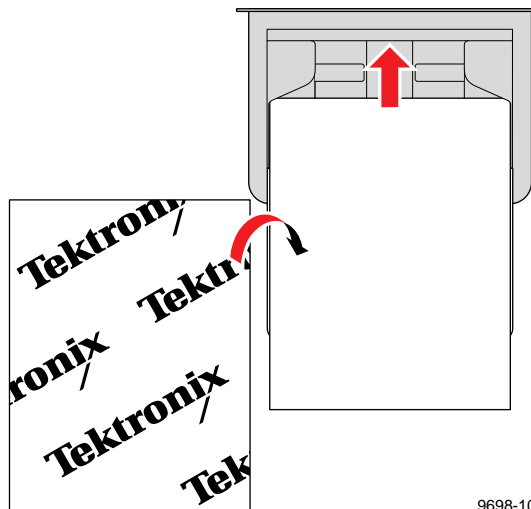

9698-102

4. In the application, reverse the image horizontally (the image must print backward to transfer correctly).

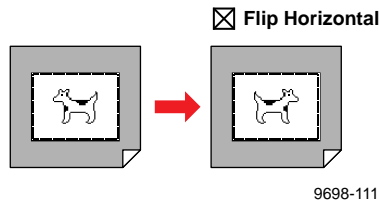

5. Use your printer driver or the front panel menu to select the Multi-Purpose Feeder and the media type (Fabric Transfer).

Caution *To avoid media jams and damage to the printer components, make sure that you follow these guidelines:*

- *For best print quality and reliability, use only Tektronix-brand Fabric Transfer media. Refer to “Supplies and accessories” on page 9-2 for ordering information.*
- *Make sure that you load only one sheet of Fabric Transfer media at a time; otherwise, the printer may report **Jam at Multi-Purpose Feeder***

Note *After printing, use a professional heat press to transfer the image. For instructions, refer to the information sheet included with the Tektronix Fabric Transfer media.*

Duplex printing

This printer allows you to print double-sided on laser paper, from the PAPER trays and the Multi-Purpose Feeder.

Caution Use laser bond paper for duplexing; two-sided printing on specialty media can shorten component life. For opacity and feed reliability, use laser paper that is at least 100 g/m² (28 lb. bond). For best results, do not use heavy toner coverage on Side 1. Also, increase the top margin on Side 1 for better feed reliability.

Double-sided printing with a PAPER tray

SIDE 1

1. Place the paper in the PAPER tray with the side to be printed *face down*; the top of the page is under the paper tray's hooks. This example shows letterhead paper.

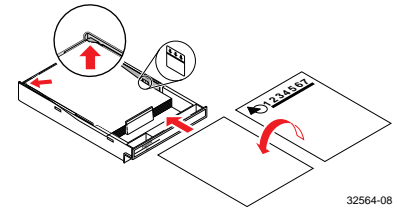

32564-08

2. Insert the PAPER tray into the printer.

If you have a Lower Tray Assembly, you can use any of the printer's media tray slots: Upper, Middle, or Lower; for these instructions, use Upper.

Note For a multi-page document, print odd-numbered pages for Side 1. (This selection is application-specific).

3. Select the tray and output order, using either (a) a supported driver or (b) the printer's front panel; then send the print job:

■ Making selections in the driver

Select the tray:	Upper	Listed under Paper Source or Tray Selection (depending on the driver).
Output Order:	Face Down	Listed under Options or TekColor Options (depending on the driver).

■ Making selections in the front panel

Select the tray	Upper	Listed under Default Tray in the Printer Defaults menu.
Output Order	Face Down	Listed under Output Order in the Printer Defaults menu.

4. Remove the printed paper from the output tray.

SIDE 2

1. Place the paper in the PAPER tray with the side to be printed *face down* (the side that has already been printed is now *face up*); the top of the page is under the paper tray's hooks.

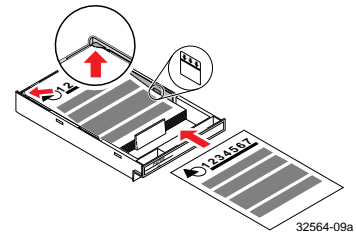

Insert the PAPER tray into the printer. If you have a Lower Tray Assembly, you can use any of the printer's media tray slots: Upper, Middle, or Lower; for these instructions, use Upper.

Note For a multi-page document, print odd-numbered pages for Side 1. (This selection is application-specific).

2. Select the tray and output order, using either (a) a supported driver or (b) a supported driver or the printer's front panel; then send the print job:

■ **Making selections in the driver**

Select the tray **Upper** Listed under Paper Source or Tray Selection (depending on the driver).

Output Order **Face Up** Listed under Options or TekColor Options (depending on the driver).

■ **Making selections in the front panel**

Select the tray **Upper** Listed under Default Tray in the Printer Defaults menu.

Output Order **Face Up** Listed under Output Order in the Printer Defaults menu.

Double-sided printing from the Multi-Purpose Feeder

Caution Use laser bond paper for duplexing; two-sided printing on specialty media can shorten component life. For opacity and feed reliability, use laser paper that is at least 100 g/m² (28 lb. bond). For best results, do not use heavy toner coverage on Side 1.

SIDE 1

1. Place the paper in the Multi-Purpose Feeder with the side to be printed *face up*. This example shows letterhead paper.

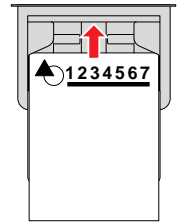

2. First, make these selections in the printer's front panel:

Default Tray: **Multi-Purpose** Listed in the Printer Defaults menu.

Media Type: **Paper** Listed under Multi-Purpose Feeder in the Printer Defaults menu.

Note For a multi-page document, print odd-numbered pages for Side 1. (This selection is application-specific).

3. Then, make this selection in a supported driver and send the print job:

Select the tray: **Multi-Purpose Tray*** Listed under Paper Source or Tray Selection (depending on the driver).

* This setting automatically selects the media type previously defined in the front panel.

4. Remove the printed paper from the output tray.

SIDE 2

Caution *When printing Side 2 for duplex printing (using the Multi-Purpose Manual Feed), always choose Paper 2nd Side as the media type. This selection is specially formulated for this purpose; choosing any other media type can reduce component life.*

1. Place the paper in the Multi-Purpose Feeder in this way:

- The blank side is *face up* (the side that has already been printed is now *face down*).
- The top of the page enters the printer *first*.

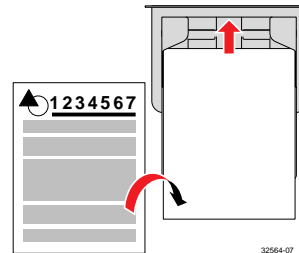

2. First, make these selections in the printer's front panel:

- Default Tray:** **Multi-Purpose** Listed in the Printer Defaults menu.
- Media Type:** **Paper 2nd Side** Listed under Multi-Purpose Feeder in the Printer Defaults menu.

Note *For a multi-page document, print even-numbered pages for Side 2. (This selection is application-specific).*

3. Then, make this selection in a supported driver and send the print job:

- Select the tray:** **Multi-Purpose Tray*** Listed under Paper Source or Tray Selection (depending on the driver).

4. Remove the printed paper from the output tray.

Printing: Beyond the Basics

Beyond the basics of printing are the printer's special features that set it apart from other printers, as well as more in-depth information on using color and getting the best results:

- Special printing features:
 - Controlling color density
 - Using the Quick Collate option
 - Previewing with Check Print
 - Image Smoothing
 - Automatic tray switching
 - Getting job information
- Working with color
- TekColor corrections — making the best selection
- Printing and using the color sampler charts

Special printing features

Controlling color density

The printer's front panel provides an interface to adjust the density of the toner applied to the media. This feature compensates for the changes in color intensity that can occur as toner cartridges or the imaging unit age. Follow these steps to adjust the color density:

1. Press the **Menu** button on the front panel. The display reads:

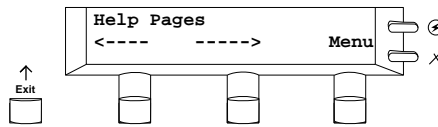

2. Press the right arrow button so that the display reads:

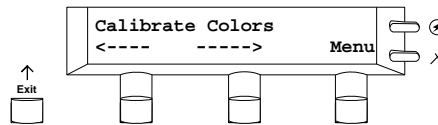

3. Press the **Menu** button to enter the **Calibrate Colors** menu.
4. Press the right or left arrow button so that the display reads:

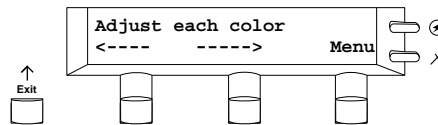

5. Press the **Menu** button. The display reads:

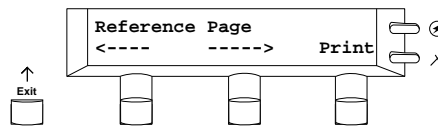

6. Press the **Print** button to print the Color Reference Page.

The current density setting for each color is indicated by the dashed line enclosure and the numeric value (-10 to +10) next to each color. The page also shows the ranges that you can select in the front panel. In the example on the next page, the density setting for each color is the default, 0.

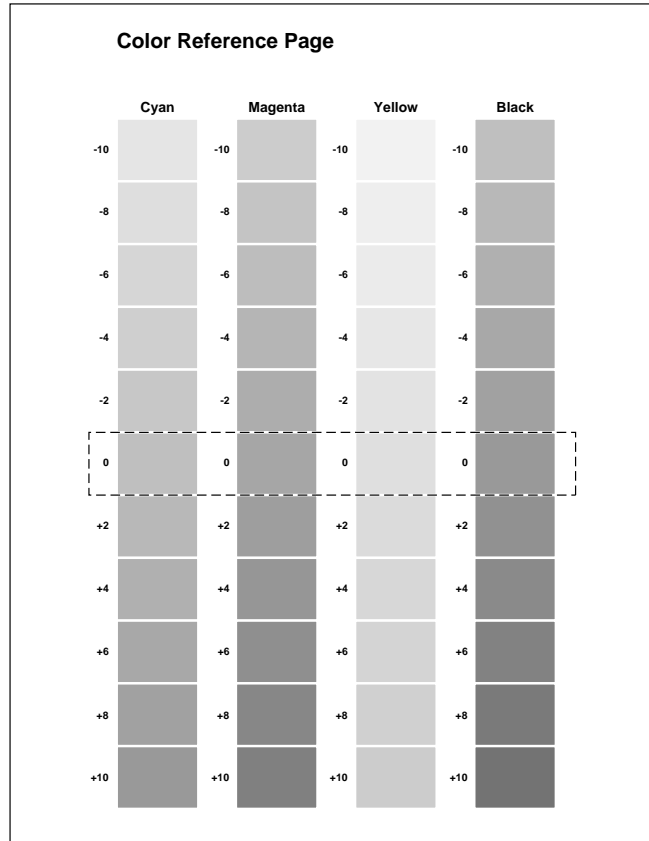

9698-17

7. Compare the printer's current density settings on the Color Reference Page with the samples on the *Color Density Samples* card (found inside the back cover pocket of the *Quick Reference Guide*).

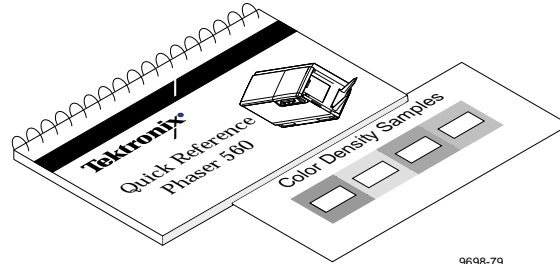

9698-79

- a. Place the Color Reference Page on at least two sheets of clean white paper in a well-lighted area.
- b. Align the hole in the cyan color density sample on the *Color Density Samples* over the cyan column on the Color Reference Page.

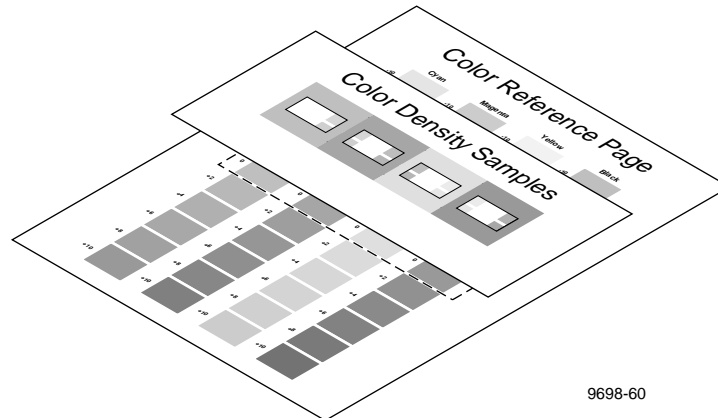

9698-60

- c. Decide which block on the Color Reference Page most closely matches the density of the cyan sample on the *Color Density Samples*. Make a note of the value (-10 to +10) associated with that block (you will need the value for Step 8).
- d. Repeat Steps b and c for each color.

8. Use the **Calibrate Colors** menu in the printer's front panel to adjust the density according to the numbers you recorded in Step 7.
 - In this example, the current setting for cyan, indicated by an asterisk, is +1.
 - To change the setting, press the left arrow button to decrease the color adjustment and the right arrow button to increase the color adjustment. Refer to the table on page 5-7 for information on these settings.

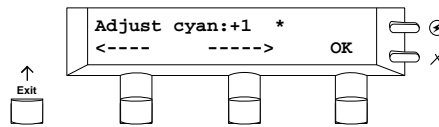

9008-4

9. After changing the density setting for any or all of the colors, reprint the Color Reference Page, which shows the following:

- The dashed line enclosure reflects the changes you made to the settings.
- In this example, the density for each color is set to a different value.

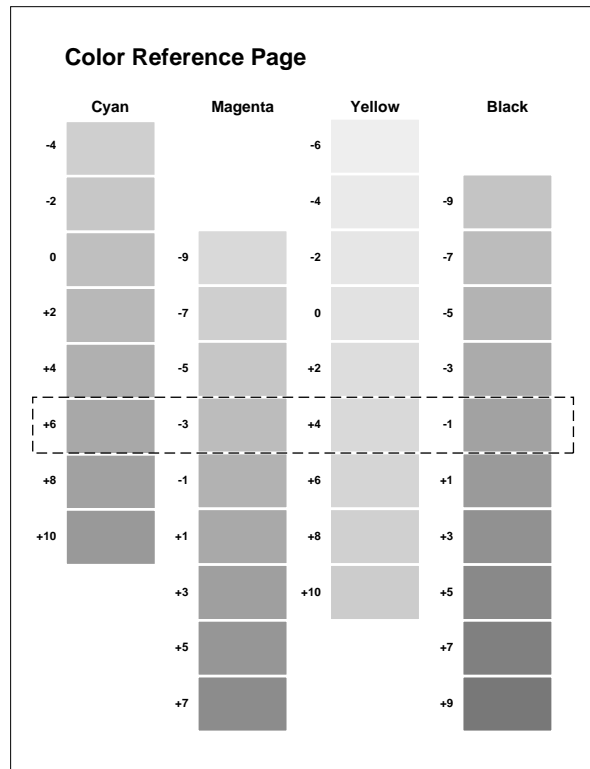

9698-18

10. When you finish adjusting the colors, press the  button until the front panel displays **Ready**.

The following table shows the selections available in the **Calibrate Colors** menu, along with a brief explanation of each function.

Calibrate Colors menu selections

Menu item*	What it does	How it works
Adjust light/dark <----> <----> Menu	Lightens or darkens all toner colors.	<ul style="list-style-type: none"> ■ Press the Menu button.
Lighter/Darker:+0 * <----> <----> OK	<p>Lightens or darkens all toner colors.</p> <p>The current Light/Dark setting reflects the <i>average value</i> of the four separate density settings. Each increment adjusts all four density values up or down the same amount. The available adjustment range is limited so that no single color exceeds the ±10 value limit.</p>	<ul style="list-style-type: none"> ■ To lighten colors, press the left arrow button (the number decrements in 1-point steps); then press the OK button. ■ To darken colors, press the right arrow button (the number increments in 1-point steps); then press the OK button.
Adjust each color <----> <----> Menu	Controls the color density for each color independently.	<ul style="list-style-type: none"> ■ Press the Menu button.
Color Reference Page <----> <----> Print	Prints a sample of the current density setting and a range of settings for each color.	<ul style="list-style-type: none"> ■ Press the Print button.
Adjust <color>: <----> <----> Menu	Enters the menu to calibrate a single color.	<ul style="list-style-type: none"> ■ Press the Menu button.
Adjust <color>:+0 * <----> <----> OK	Calibrates the indicated color.	<ul style="list-style-type: none"> ■ To lighten this color toner, press the left arrow button (the number decrements in 1-point steps); then press the OK button. ■ To darken this color toner, press the right arrow button (the number increments in 1-point steps); then press the OK button.
Reset adjustments <----> <----> Menu	Resets the color calibration to the default settings.	<ul style="list-style-type: none"> ■ Press the Menu button; then press the Confirm button.

* An asterisk (*) on the front panel selection indicates the current setting.

Using the Quick Collate option

The Quick Collate option in the supported drivers performs document collation *in the printer*. This is faster than the Collate option that exists in some applications because applications send each page to the printer in sequence, as many times as necessary to provide the requested number of copies. With the printer's Quick Collate option, the job is *sent only once*, and then multiple collated sets are produced *by the printer*.

Note The Quick Collate option is only available with the Extended Features configuration of the printer.

Application collation

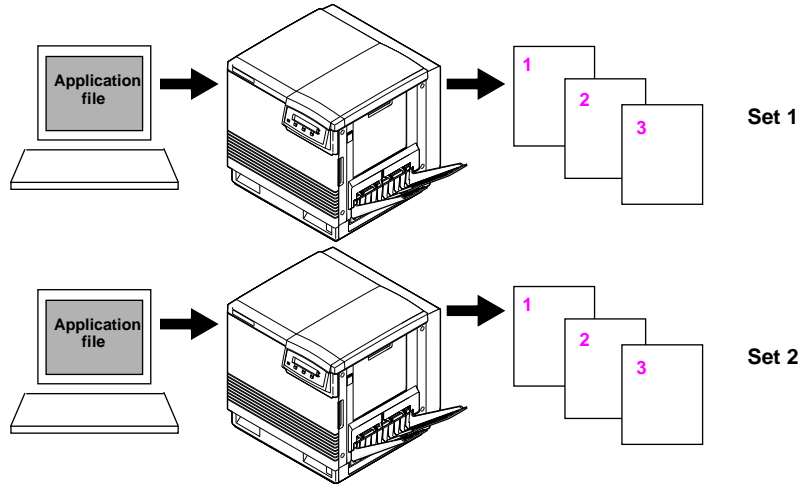

Phaser 560 Quick Collate

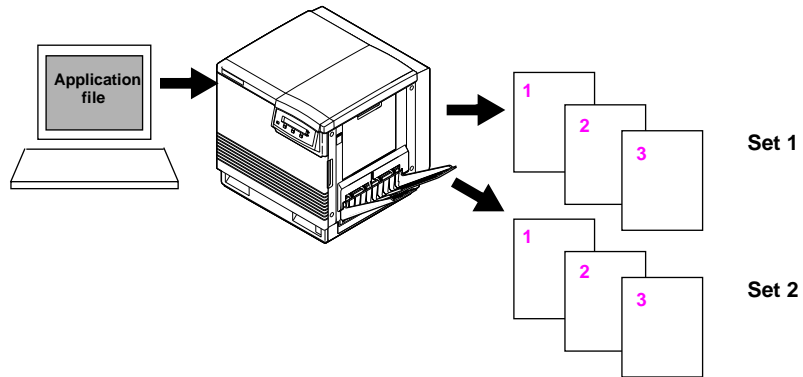

The number of pages that can be collated at one time depends on these factors:

- Printer's memory configuration.
- Presence and size of a hard disk attached to the printer.
- Complexity of the pages to be collated.

According to these factors, the printer collates in sequential sets as many pages as will fit in the available memory. For example, you have a 6-page job and you request 4 copies. Because the fourth page is complex and consumes all available memory, only the first three pages fit in the printer's (or hard disk's) available memory. The fifth and sixth pages are relatively small. In this case, the printer divides this job into three segments and prints in this manner:

1 4 sets of pages 1, 2, and 3

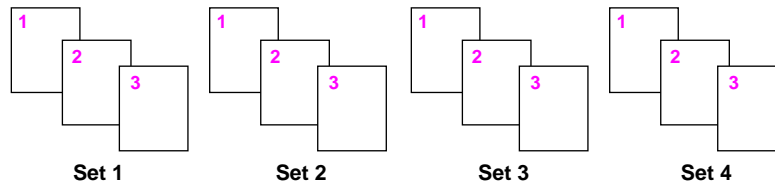

2 4 copies of page 4



3 4 sets of pages 5 and 6

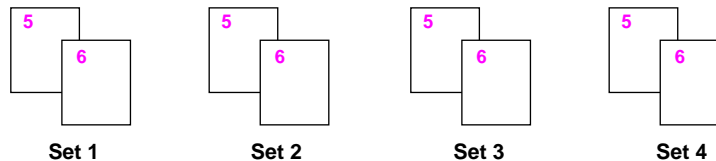

Collation hints and tips

Output order

Make sure that you select Output Face Down or uncheck the Output Face Up box, depending on the driver you are using.

Increasing the collation capacity

To increase the number of pages that the printer can collate at one time, consider one or more of the following changes:

- Increase the printer's memory.
 - ZMA16** 16-Mbyte SIMM (Option 16)
 - ZMA32** 32-Mbyte SIMM (Option 32)
- Attach a hard disk to the printer's SCSI port.
- Increase the size of an existing hard disk.

Recommended: *At least 40 Mbytes of memory and an external hard disk. Refer to "Expanding your printing system" on page 9-5 for ordering information.*

Quick Collate and the Check Print option

When you use the printer's Quick Collate option in combination with the Check Print option, only the first page of the first set is printed before pausing for review.

Previewing with Check Print

This feature is available only with the printer's Extended Features configuration. When sending a multiple-page file to the printer through the driver, you can select Check Print to preview the first page of the job and determine if the print is to your liking before proceeding with the remainder of the job. This is especially useful when printing a large job.

The ability to access Check Print from the driver is enabled and disabled in the printer's front panel. You can also set the timeout in the front panel (the timeout is the amount of time the printer will wait after sending the first page of a file, before it continues with the remainder of the job).

The factory default for Check Print is disabled; the default timeout is 5 minutes. Follow these instructions to enable Check Print in the front panel and select the option in the printer driver:

1. While the **Ready** message is displayed in the front panel, press the **Menu** button. Use the left arrow (<-->) or right arrow (--->) buttons to scroll through the selections until the following message appears:

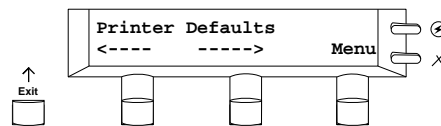

9008-43

2. Press the **Menu** button. Use the arrow buttons to scroll through the selections until the following message appears:

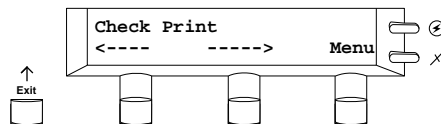

9008-43

3. Press the **Menu** button. The following message appears:

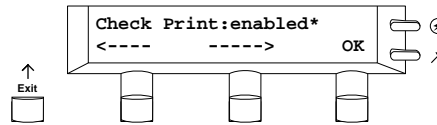

9008-43

The asterisk (*) indicates the current setting. By default, Check Print is enabled. Pressing an arrow button toggles the selection between *enabled* and *disabled*. Pressing the **OK** button activates the new selection.

4. To change the Check Print Timeout (the amount of time the printer pauses before completing the print job), press the **Menu** button when the front panel displays **Check PrintTimeout**. The front panel displays this message:

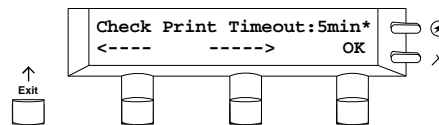

9008-43

5. Press the arrow buttons to scroll through a list of pre-set timeouts: 1, 2, 5, 10, 20, 30 minutes, 1 hour, 8 hours, 24 hours, and Infinite. The asterisk (*) indicates the current setting. Press **OK** to activate your selection.

6. Select Check Print in a supported driver.
 - LaserWriter 8 driver:
Select the Check Print option in the Options dialog box available by clicking the Options button in the Print dialog box.
 - Phaser 560 driver:
Select the Check Print option in the TekColor dialog box by clicking the TekColor button in the Print dialog box.
 - Phaser 560 GX driver:
Select the Check Print option in the TekColor printing extension in the Print dialog box (or in the Printer Driver Defaults dialog box available from the Printing menu).
 - Windows 95 PostScript driver:
Select Check Print options in the Printer features field in the Device Options tab options.
 - Adobe PS3 driver for Windows 3.1:
Select Check Print options in the Features tab options.
7. Check your first print. At the **Check Print** message on the printer's front panel, press one of the buttons:
 - **Reprint** Reprints the first page, then the printer pauses again for the duration of the selected timeout or until you press one of the buttons.
 - **Cancel:** Cancels the print job.
 - **Continue** Continues printing the entire print job.

Image Smoothing

Image Smoothing is selected from the printer's front panel (in the **PrinterDefault** menu) as well as in supported printer drivers. Image Smoothing blends adjacent colors in an image so that color transitions are less noticeable.

This feature is typically used when the image being printed is at a lower resolution than the printer's output resolution. For example, printing an image downloaded from the World Wide Web at 72 dpi using the printer's 600 or 1200 dpi. Images printed using Image Smoothing appear with less sharp detail but with smoother color transitions. Image Smoothing does not affect images downloaded at more than half the printer's resolution. Due to extra internal printer calculations, printing may take longer with Image Smoothing on.

Options

- **On**
- **Off** (*default*)

Hints

- ▼ If you do not have a supported printer driver, you can use the PostScript utility files shipped on the printer's CD-ROM or diskettes. Refer to the on-line manual on the printer's CD-ROM for instructions on downloading utility files.

Automatic tray switching

When your printer has a Lower Tray Assembly installed, you can easily run large jobs without having to replace media often.

1. For automatic tray switching to work properly, make sure that you have three of the same media trays.
2. Load the same *type* and *size* media (for example, A4 paper) in three identical media trays.
3. Install a tray in each of the trays slots in the printer.
4. Select the media tray by *type* (PAPER, TRANSPARENCY, or LEGAL) in either the printer's front panel or the printer driver.

Getting job information

The printer's front panel includes an **Info** button that provides the following information for a particular print job:

- Printer Name
- User Name
- Print Server
- IP Address of your printer
- Job Name

To access this information, follow these steps:

1. Press the **Info** button on the front panel.

The printer displays the first message.

2. Press **More** to view each of the subsequent messages.

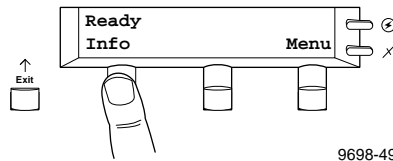

The **Info** button also provides important information when the printer requires user interaction. Refer to “Printer information” on page 8-5 for details.

Working with color

Whether you are producing color reports, memos, graphs, charts, overhead transparencies for presentations, color handouts, or design comps, there are a few things to keep in mind when using color.

- A large area of color looks more saturated (brighter) than a small area of the same color.
- A color looks brighter against a dark background than it does against a white background.
- Colors look different due to the background color or to the surrounding colors.
- The appearance of a color varies with the type and amount of light, for example fluorescent lighting versus sunlight.

General guidelines

- Keep a document or design simple and consistent.
- Select colors that look good together and that reinforce your message.
- Check your application for standard palettes to get you started.
- Use a color scheme of five or six shades, and in a series of images, use the colors in a consistent manner throughout the series.
- Use color to highlight the most important information, such as a bar or pie segment in a chart or graph.
- Use color to show relationships between objects, such as a range of values. Objects with a similar meaning or value should be in similar colors.
- Use color as graphic elements in the design of newsletters, logos, and brochures.
- Avoid red and green combinations; these colors are hard for people with red/green color blindness to distinguish.
- Avoid red and blue combinations; these colors cause the eyes to focus at different lengths.

Color corrections — making the best selection

TekColor corrections

The printer's TekColor color correction options provide simulations of different color devices. Follow these basic guidelines so that the printer accurately reproduces the colors you want on your prints.

- For general-purpose printing, select the Automatic color correction, which adjusts the color quality for the best reproduction and print speed of each page in a document.
- For prints containing only graphics, use the Vivid Color option.
- For engineering and scientific imaging applications, try printing with the Simulate Display or Vivid Color option.
- For graphic arts purposes, there are three printing press standards to choose from: SWOP Press (Specifications for Web Offset Publications), Commercial Press and Euroscale Press.

Color corrections can be selected from printer drivers, set in the printer with downloadable utility files, or set from the printer's front panel.

TekColor color corrections are performed in the printer. To use ColorSync color matching on a Macintosh, or to use host color correction in Windows 95, refer to the topics on the printer's CD-ROM or the Tektronix World Wide Web site.

Note *TekColor color corrections do not affect colors specified in the PostScript Level 2 international color standard CIE XYZ developed by the Commission Internationale de l'Eclairage (International Commission on Illumination).*

Deciding which color correction to use

Color printers and computer display screens produce color differently. Printers use the subtractive primaries CMYK (cyan, magenta, yellow, and black), and produce color when light is reflected off the paper. Computers use the additive primaries RGB (red, green, blue) with a light-emitting CRT screen. The printer and the computer screen each have a different range of possible colors they can produce, with some overlap between them.

Software application packages specify color in different ways, for example as CMYK or RGB, or they may give you a choice. Get to know your applications so you can work more efficiently.

The TekColor color correction options are available for a finer degree of control over color. Since no single color correction option can address all uses, refer to the following table for the description that best fits your printing situation, and try the suggested color correction.

Color correction solutions

Printing objective or problem	Color correction to use
General-purpose printing	Automatic
Turn off all color corrections	None
Using PANTONE Colors	
Brightest, most vibrant colors	
Overhead transparency presentations	Vivid Color
Blue colors are printing too purple	
Colors are washed out or faded	
Colors should match computer display screen*	Simulate Display
Colors are too dark	
Colors should match a printing press standard	SWOP Press Euroscale Press Commercial Press
Use printer's current color defaults	Use Printer Setting
Use Adobe's standard color conversions for speed	Downloadable utility files: <i>Monochrome</i> <i>Raw CMYK</i> <i>Raw RGB</i>

* For other ways of matching the screen's colors, use ColorSync color matching on a Macintosh or use host color correction in Windows (refer to the topics on the printer's CD-ROM or on the Tektronix World Wide Web site).

Color correction descriptions

General all-purpose printing

The Automatic option is the best choice for typical office printing. This option automatically adjusts the color correction used for each page, according to which elements (for example images, graphics) are included on that page.

Turning off all color corrections

If you do not want to use any TekColor color corrections, you can specify None from a supported driver, with utility files, or from the printer's front panel. Select None when you are doing the following:

- Using applications that do their own color adjusting
- Using ColorSync on a Macintosh or host color correction in Windows 95
- Printing printer-specific PANTONE Colors

Note *For more information on PANTONE Colors, refer to the topics on the Tektronix Color Printer World Wide Web site:*

`http://www.tek.com/Color_Printers/support/`

Printing the brightest colors and a truer blue

The Vivid Color option makes printed blue appear less purple by reducing the amount of magenta used to print blue colors. Other colors in the cyan-blue-purple-magenta range in the image are also adjusted to compensate for the adjusted blue. Colors in the red-orange-yellow-green range are not affected. This selection is good for making presentation graphics, such as overhead transparencies, and for bright-looking colors that don't need to match the screen's colors or printing press colors.

Vivid Color adjusts CMYK colors using a method that adds black to other components. This option prints more saturated (darker) colors and may be useful for printing overhead transparencies for presentations from some applications, such as CorelDRAW!. Use this option if you have specified a color in the CMYK system, *and* the color has a black component, *and* the color appears lighter than you expected when printed.

Simulating display screen colors

The Simulate Display option makes printed colors approximate the colors on a standard display screen. This selection should improve the screen-to-printer color accuracy for most applications that don't perform their own color corrections. This selection is best for applications that define colors as RGB (red, green, blue), HLS (hue, lightness, saturation), or HSB (hue, saturation, brightness).

Closely match printing press colors

There are three printing press color correction options. Each press option conforms to a different printing standard. Use a press option if you are previewing work for a four-color job to be printed on a printing press. These options simulate a four-color commercial printing press, *not* solid spot colors, such as PANTONE PMS Colors.

Note *If you are selecting printer-specific PANTONE Colors in your application, use the None option; see “Turning off all color corrections” on page 5-20. Also, use the None option with other color management systems, such as EfiColor.*

Printing press color corrections

Press option	Inks	Base (paper)	Target match (equivalent 3M Matchprint®)
SWOP Press	SWOP/soy	publication	<p>Specification for Web Offset Publications</p> <p>These are specifications for color separation films and color proofing that are used to ensure the consistency of printed colors between different publications. This option is typically used in the U.S., and is characterized to match 3M Matchprint® 3 publication proofs.</p> <p>Used for high-volume, web press printing.</p>
Commercial Press	commercial	commercial	<p>This option is typically used in the U.S., and is characterized to match 3M Matchprint commercial proofs.</p> <p>Used for high-quality, sheet-fed printing.</p>
Euroscale Press	Euroscale	publication	<p>This option is typically used in Europe, and is characterized to match the equivalent 3M Matchprint 3 proof.</p>

Using the printer's current color defaults

The Use Printer Setting option is available only in the supported drivers. This option sends no color correction information to the printer. It uses the current default in the printer to process colors for printing. The factory default color correction is Automatic. The printer's default can be one of the following:

- Any option selected in the TekColor Corrections menu on the printer's front panel.
- One of the color correction utility files sent to the printer.

Using simple color conversions

The following utility files use Adobe's standard color conversions to tell the printer to pipe colors through as fast as possible:

- *Monochrome (MONOCHR.PS)*: Converts all colors to grays. Use this file with the Fast Monochrome print-quality mode for the fastest possible throughput.
- *Raw CMYK Colors (RAWCMYK.PS)*: Converts all colors (CMYK, RGB, grays) to CMYK colors. Use this file if your application specifies colors as CMYK (cyan, magenta, yellow, and black). This file lets you control the CMYK output of the printer's colors without using any TekColor color corrections. Use this file with the Fast Color print-quality mode to increase throughput.
- *Raw RGB Colors (RAWRGB.PS)*: Converts all colors (CMY, CMYK, grays) to RGB colors. Use this file if your application specifies colors as RGB (red, green, and blue). This file lets you control the CMY output of the printer's colors without using any TekColor color corrections. Use this file with the Standard print-quality mode to increase throughput.

Note Refer to the on-line documentation on the printer's CD-ROM for instructions on installing and using the utility files.

Special considerations

If your Phaser 560 printer is shared on a network

Another user may use the downloadable color correction utility files, or the printer's front panel, to change the printer's default color correction setting. If this situation occurs, the prints you make through a non-supported driver may not print as expected. Refer to "Sharing the printer on a network" on page 7-36 for details on how the color corrections interact with the driver settings for either supported or non-supported drivers.

Application color corrections

Some applications perform color corrections to improve screen-to-printer color matching. The TekColor color correction options in the supported drivers adjust colors in the printer after the application has performed its color corrections.

- If the application uses CIE (Commission Internationale de l'Eclairage) colors, the TekColor corrections will *not* be applied.
- If you select a TekColor color correction option in a driver other than None, the selection may override some application features.
- If you try one of the TekColor color correction options in a supported driver and the printed results are not what you expected, then select the None option and try reprinting your image.
- Select the None TekColor color correction option in a supported driver if you are using ColorSync color matching on a Macintosh or host color correction in Windows 95 (refer to the CD-ROM or World Wide Web ColorSync topics).

If you are using an unsupported driver

To use the color corrections with an unsupported driver that does not use PPDs, use the downloadable utility files or the printer's front panel.

Printing and using the color sampler charts

You can print color sampler charts from your printer to see how the colors, as specified from within an application, will look when printed. Having a pre-printed sample of each color can help you save time in selecting the right color for your use.

The printer's color sampler files are available from a variety of sources, according to the following table:

Printing color sampler charts

Color Sampler Charts	Accessing the charts	
<p>CMYK Sampler</p> <p>Cyan, magenta, yellow, and black color model</p>		
<p>RGB Sampler</p> <p>Red, green, and blue color model</p>	<p>Print from CD-ROM and Diskettes <i>or</i></p>	<p>Download from World Wide Web</p>
<p>HSB Sampler</p> <p>Hue, saturation, and brightness color model</p>		<p>See "Printing the Color Sampler Charts" on the CD-ROM.</p>
<p>PANTONE Sampler</p> <p>The PANTONE Color Lookup Table for the Phaser 560 printer</p>		

The color chart you print and use depends on how the application you are using selects color. Refer to the application's documentation for information on color selection, then print one or more of the color charts listed in the table below.

Color sampler chart files

Color sampler chart	Number of printed pages	Macintosh file name	PC file name
CMYK colors	18	<i>CMYK Sampler</i>	<i>CMYK.PS</i>
RGB colors	12	<i>RGB Sampler</i>	<i>RGB.PS</i>
HSB colors	12	<i>HSB Sampler</i>	<i>HSB.PS</i>
PANTONE Colors	46	<i>PANTONE® Phaser 560.ps</i> <i>PANTONE® Phaser 560.pdf</i>	<i>PANT560.PS</i> <i>PANT560.PDF</i>

The color sampler charts are made up of areas of color with each color's components listed below it. Each color sampler chart is several pages long; they are printed in panels that can be connected to form a wall chart or placed in a binder for easy reference.



Caring for Your Printer

Overview

To ensure the best print quality and the most reliable printer operation, follow these simple guidelines:

- Always use high-quality paper and *only* Tektronix-brand Transparencies, Glossy Coated paper, and Fabric Transfer media.
- To maintain print quality, use the troubleshooting information in this book and the *Quick Reference Guide*, as well as the Consumables Page and Service Print 1 in the front panel's **HelpPages** menu.
- Double-sided printing and specialty media will require more frequent cleaning of the rollers and will reduce the average life of the consumables.

Caution *Keep the Imaging Unit's light exposure to a minimum — less than 90 seconds of artificial light and no exposure to sunlight — or you may damage the unit:*

- *When installing a new Imaging Unit, keep the protective plastic sheet on until immediately before inserting the unit.*
- *If, when installing the Imaging Unit, you also need to install other components, install the Imaging Unit last to minimize its light exposure.*
- *When changing a toner cartridge or clearing a media jam, make sure that you close the printer's right side door quickly to avoid any light exposure to the Imaging Unit.*
- *Do not leave the printer's front door open for extended periods of time (for example, several hours).*
- *Do not touch the underside or the right side of the Imaging Unit; fingerprints may appear on your output.*
- *Use only laser paper for double-sided printing; other media may damage printer components.*

User-replaceable components

This printer is designed modularly so that it is easy to maintain: several of the components are replaceable. Cleaning is only necessary if you experience frequent media jams (see “Cleaning the paper-pick and paper-feed rollers” on page 6-12).

These are the replaceable components for the printer:

1. Transfer Kit (transfer roller/waste bin)
2. Imaging Kit (Imaging Unit and filter)
3. Fuser Roll
4. Fuser
5. Toner Cartridges
6. Main Charge Grid

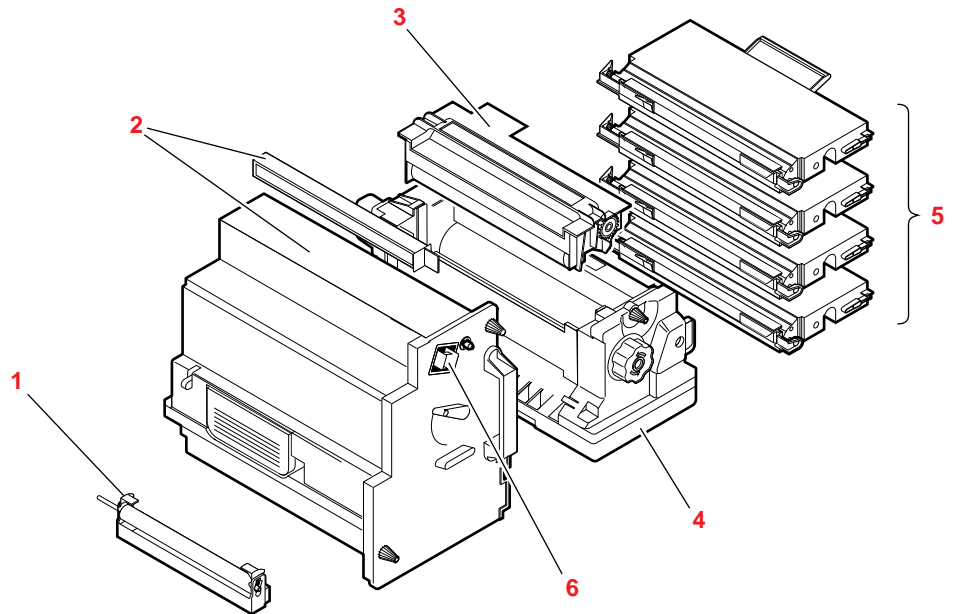

When to replace components

When the printer's front panel indicates that a component needs to be replaced, make sure that you have replacements on hand. The printer may continue to print until the component is completely used up; for the toner and Fuser Roll, the printer stops until you replace them. The Imaging Unit and Fuser continue to print.

Printer component	Front panel message	Average life*	Order number	
TONER CARTRIDGES 	<color> low Change the color toner soon.	10,000 pages (CMY)**	Black	016-1536-00
	Stopped: Replace:<color> Change the color toner now .	12,000 pages (Black)**	Magenta	016-1537-00
IMAGING UNIT 	Imaging Unit:replace Change the Imaging Unit soon.	57,000 images or 14,250 color pages		016-1523-00
	Imaging Unit expired Change the Imaging Unit now .	60,000 images or 15,000 color pages		
FUSER 	Fuser:replace Change the Fuser soon.	27,000 pages	110 Volt	016-1534-00
	Fuser expired Change the Fuser now .	30,000 pages	220 Volt	016-1535-00
FUSER ROLL 	Fuser Roll:replace Change the Fuser Roll soon.	15,000 pages		016-1556-00
	Stopped: Fuser Roll:replace Change the Fuser Roll now .	15,500 pages		
TRANSFER KIT 	Transfer Kit:replace Change the Transfer Kit now .	60,000 pages		016-1533-00

* These figures are based on an average of 5% coverage of the printable area for any one color using laser paper. The frequency of replacement will vary, depending on the complexity of the prints, the percentage of coverage, and the type of media. Transparencies, glossy coated paper, and other specialty media will result in shortened consumable life.

** The starter cartridges that are shipped with the printer have an average life of approximately 3,000 pages, based on an average of 5% coverage.

Consumable life information

This printer provides several convenient methods for accessing the information you need on the life of the user-replaceable components.

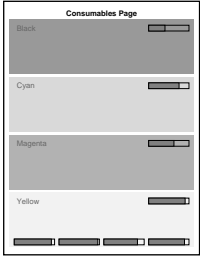
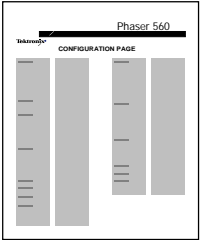
Resource	Information provided	How to access
<p>Consumables Page</p> 	<p>% Remaining gauge for each of the following:</p> <ul style="list-style-type: none"> ■ Toner (each color has its own gauge) ■ Imaging Unit ■ Transfer Kit ■ Fuser ■ Fuser Roll 	<p>To Print:</p> <ol style="list-style-type: none"> 1. Press the Menu button on the front panel. 2. Press Menu again to access the Help Pages menu. 3. Press an arrow button (<--- or --->) to scroll through the selections until Consumables Page appears. 4. Press the Print button.
<p>Configuration Page</p> 	<p>Copy Count for each of the following:</p> <ul style="list-style-type: none"> ■ Imaging Unit ■ Transfer Roller ■ Fuser ■ Fuser Roll <p>% Average Coverage:</p> <ul style="list-style-type: none"> ■ Toner (each color has its own %) 	<p>To Print:</p> <ol style="list-style-type: none"> 1. Press the Menu button on the front panel. 2. Press Menu again to access the Help Pages menu. 3. Press an arrow button (<--- or --->) to scroll through the selections until Configuration Page appears. 4. Press the Print button.

Replacing the components

This section describes the *basic* steps for removing and installing the replaceable components. *Detailed, illustrated* instructions are shipped with each of the replaceable components.

Toner cartridges

Front panel messages

<color>: low

- Replace the designated color toner cartridge soon. After the message appears, the cartridge may still yield about 700 pages, depending on the complexity of your prints.

Stopped:replace <color>

- Replace the cartridge **now**; it is empty and the printer stops until you replace the cartridge.

Diagnosing print quality

- Uneven, streaky or mottled color.
- Faded or missing color in a single color.
- One or more straight and even, vertical, light or dark streaks in one color.
- Print the **Consumables Page** from the front panel.
 - Check the **% Remaining** gauge.
 - Compare your output with the print quality examples in “Maintaining print quality” on page 7-6 to diagnose and correct the symptoms.
- Print the **Configuration Page** from the front panel or access the front panel **System Counts** menu.
 - Check the color toner **Count**; compare the number to the component’s average life (refer to page 6-3).

Replacing a toner cartridge

1. Remove the new toner cartridge from its packaging.
2. Remove all tape and the protective sheet; then remove the plastic shipping cover from the cartridge.
3. Remove any media from the output tray.
4. Open the printer’s right side door; remove the empty cartridge and discard it as normal office waste.
5. Insert the new cartridge and close the printer’s right side door.

Caution *Because the printer keeps track of the toner usage when a new cartridge is installed after the front panel has reported <color>: low, if you switch toner cartridges between printers the % Remaining counts will not be correct.*

Imaging unit

Front panel messages

Imaging Unit:replace

Replace the Imaging Unit soon. After the message appears, the unit may still yield about 1,500 color pages, depending on the complexity of your prints.

Imaging Unit expired

Replace the unit **now**; it is used up and print quality is affected.

Diagnosing print quality

- Dark, vertical streaks on the print.
 - Dark color spots and streaks in all colors.
 - A wide, light, horizontal band in one place on the page.
 - All colors are faded; fine line detail disappears.
- Print the **Consumables Page** from the front panel.
 - Check the **% Remaining** gauge.
 - Compare your output with the print quality examples in "Maintaining print quality" on page 7-6 to diagnose and correct the symptoms.
 - Print the **Configuration Page** from the front panel or access the front panel **System Counts** menu.
 - Check the **Imaging Unit Count**; compare the number to the component's average life (refer to page 6-3).

Replacing the imaging kit

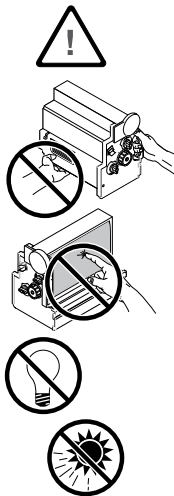

9698-103

1. Open the printer's front door.
2. Unlock the Imaging Unit:
 - Loosen the two thumbscrews (turn **counterclockwise**).
 - Turn the lower lever **counterclockwise**.
3. Remove the old Imaging Unit and cover it completely to prevent damage from light exposure.* After you determine that the new Imaging Unit corrects the symptom, dispose of the used unit as normal office waste.
4. Unpack the new unit and filter; do not touch the right side or underside of the Imaging Unit.
5. Replace the filter.
6. Insert the new Imaging Unit:
 - Turn the unit's upper lever **90° clockwise**.
 - Remove the protective plastic sheet.
 - Slide the unit into the printer; turn the lower lever **180° clockwise** and tighten the thumbscrews. Close the printer's front door.

* If installing a new unit does not correct the symptom:

1. Remove the new unit from the printer and carefully repack it for future use (it must be protected from light exposure).
2. Re-install the original Imaging Unit.

Fuser

Front panel messages	Fuser:replace	Replace the Fuser soon. After the message appears, the Fuser may still yield about 3,000 pages, depending on the complexity of your prints.
	Fuser expired	Replace the Fuser now ; it is used up and print quality is affected.

Diagnosing print quality	<ul style="list-style-type: none"> ■ Vertical scratches on the print. ■ Dark vertical scratches on the unprinted portion of the page. ■ A piece of the printed image is missing and reappears out of place. 	<ul style="list-style-type: none"> ■ Print the Consumables Page from the front panel. <ul style="list-style-type: none"> ■ Check the % Remaining gauge. ■ Print the Configuration Page from the front panel or access the front panel System Counts menu. <ul style="list-style-type: none"> ■ Check the Fuser Count; compare the number to the component's average life (refer to page 6-3).
---------------------------------	----------------------------------------------------------------------------------------------------------------------------------------------------------------------------------------------------------------------------------------------	------------------------------------------------------------------------------------------------------------------------------------------------------------------------------------------------------------------------------------------------------------------------------------------------------------------------------------------------------------------------------------------------------------------------------------------------------------------------------------------------------------------

Replacing the Fuser



1. Open the printer's front door.
2. Loosen the Fuser's thumbscrew (turn **counterclockwise**) and remove the Fuser. Dispose of it as normal office waste.
3. Unpack the new Fuser.
4. Insert the new Fuser; tighten the thumbscrew (**clockwise**). Close the front door.

Note *Each replacement Fuser includes a Fuser Roll.*

Fuser Roll

<p>Front panel messages</p>	<p>Fuser Roll:replace</p> <p>Stopped: Fuser Roll:replace</p>	<p>Replace the Fuser Roll soon. After the message appears, the Fuser Roll may still yield about 500 pages.</p> <p>Replace the Fuser Roll now; the printer stops until you replace the Fuser Roll.</p>
<p>Diagnosing print quality</p>	<ul style="list-style-type: none"> ■ A piece of the printed image is missing and reappears out of place. ■ A piece of the printed image appears faded. ■ If media frequently wraps around the Fuser. 	<ul style="list-style-type: none"> ■ Print the Consumables Page from the front panel. <ul style="list-style-type: none"> ■ Check the % Remaining gauge. ■ Print the Configuration Page from the front panel or access the front panel System Counts menu. <ul style="list-style-type: none"> ■ Check the Fuser Roll Count; compare the number to the component's average life (refer to page 6-3).
<p>Replacing the Fuser Roll</p>	<ol style="list-style-type: none"> 1. Open the printer's front door and remove the Fuser. 2. Unlock the Fuser Roll by pressing outward on its tabs; remove the Fuser Roll and dispose of it as normal office waste. 3. Unpack the new Fuser Roll. Be careful not to touch the oiled cloth. 4. Place the new roll into the Fuser; press down firmly on the roll with both hands to lock it into place. 5. Slide the Fuser into the printer and tighten the thumbscrew. Close the printer's front door. 	



Note *A Fuser Roll is always included with each replacement Fuser.*

Transfer kit

Front panel messages

Transfer kit:replace

Replace the Transfer Kit (roller/waste bin) soon.

Diagnosing print quality

- Toner spots appear on the back side of the media.
- Repeated light spots.
- Print the **Consumables Page** from the front panel.
 - Check the **% Remaining** gauge.
- Print the **Configuration Page** from the front panel or access the front panel **System Counts** menu.
 - Check the **Transfer Kit Count**; compare the number to the component's average life (refer to page 6-3).

Replacing the Transfer Kit

1. Open the printer's left side door; use the blue handles to pull out the paper feeder.
2. Lift the cover of the paper feeder. Remove the transfer roller/waste bin; place it on a piece of paper on a flat surface.
3. Lock the roller onto the waste bin by placing a piece of paper over the roller and pressing down until it snaps tight; rotate the handles *down* to lock the roller in place. Dispose of the old Transfer Kit as normal office waste.
4. Take the new Transfer Kit from its packaging and lower it into the paper feeder. Rotate the handles *down*. Make sure that the roller/waste bin is seated evenly into the opening (otherwise, the paper feeder will not close).
5. Lower the paper feeder cover and press on it to lock it in place.
6. Slide the paper feeder back into the printer and close the printer's left side door.
7. Reset the copy count on the front panel:
 - The front panel displays this message:

```
New Transfer Kit?
No           Yes
```
 - Press the **Yes** button, then press the **confirm** button to automatically reset the copy count.

Note *If you changed the Transfer Kit before the front panel reported a need to replace it, you will have to reset the copy count manually:*

- Press the **Menu** button to enter the menu.
- Navigate to the **Transfer Kit** count menu; press **Reset**; press **Confirm**.

Main Charge Grid

Each Imaging Unit includes a Main Charge Grid already installed as a component. Although the Main Charge Grid is not considered a consumable (because it typically does not wear out before replacing the entire Imaging Unit), you may need to replace it occasionally. It is recommended that you keep one on hand (order number 118-9070-02).

Illustrated instructions are shipped with each Main Charge Grid.

Use the print quality samples (page 7-13) to identify the symptoms of a worn Main Charge Grid.

Front panel messages

N/A

Diagnosing print quality

- Light vertical streaks appear in all colors (most easily visible in yellow).
- Dark and wavy vertical streaks appear in all colors (most easily visible in yellow).
- Replace the Main Charge Grid.

Replacing the Main Charge Grid

1. Open the printer's front door.
 2. Remove the used Main Charge Grid and discard it as normal office waste.
 3. Insert the new Main Charge Grid.
 4. Close the printer's front door.
-

Occasional cleaning

Regularly scheduled cleaning is not necessary for this printer. However, if your printer experiences frequent media jams, clean the paper-pick rollers (a) and the paper-feed rollers (b) on the Lower Tray Assembly.

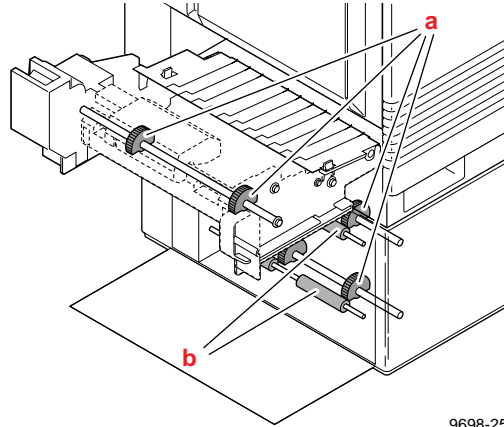

9698-25

Caution *When using isopropyl alcohol with a lint-free cloth, make sure that the alcohol is at least 90% pure, obtainable from your local pharmacy. (Never use rubbing alcohol; it can damage the printer.) You can also use pre-soaked alcohol wipes (order number 006-7824-01).*

Cleaning the paper-pick and paper-feed rollers

Note *If you have a Lower Tray Assembly, you may also need to clean the rollers for the middle and lower media trays, which are accessed by the lower left side door. Refer to the procedure on page 6-14.*

1. Slide the media tray(s) out (you do not have to remove them) to allow access to the paper-pick and paper-feed rollers.

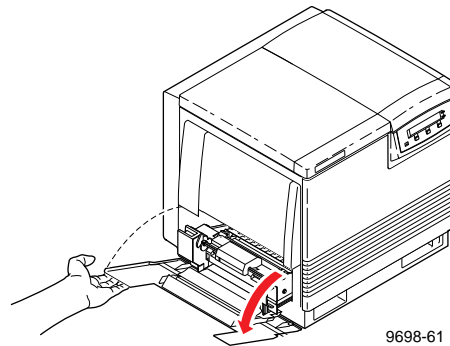

2. Open the left side door to access the rollers (if you have the Lower Tray Assembly, open the *upper* left side door).

Caution *Do not clean the transfer roller; alcohol and pressing on the roller can damage the roller and cause print-quality problems.*

3. Use the blue handles to pull out the paper feeder.

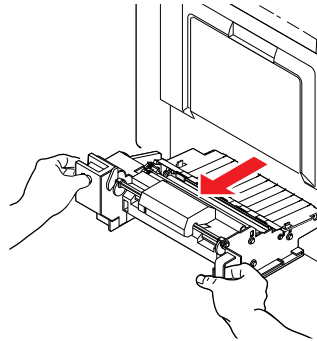

9698-26

4. Gently rotate the paper-pick rollers 180° (the paper-pick rollers are D-shaped) and wipe them with a lint-free cloth that has been moistened with isopropyl alcohol.

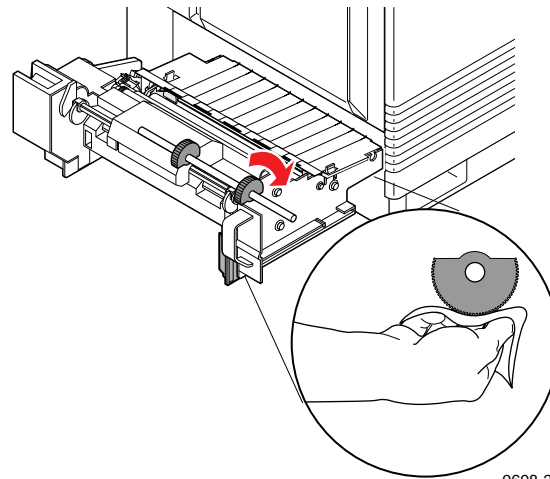

9698-28

5. Close the paper feeder and the left side door.

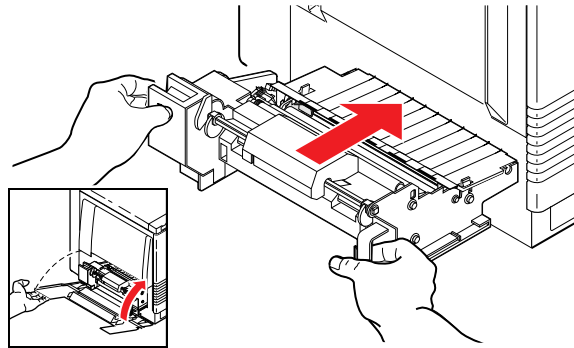

9698-29

6. Insert the media tray (if you have the Lower Tray Assembly, insert the *upper* media tray).

If you have a Lower Tray Assembly

1. Open the *lower* left side door.

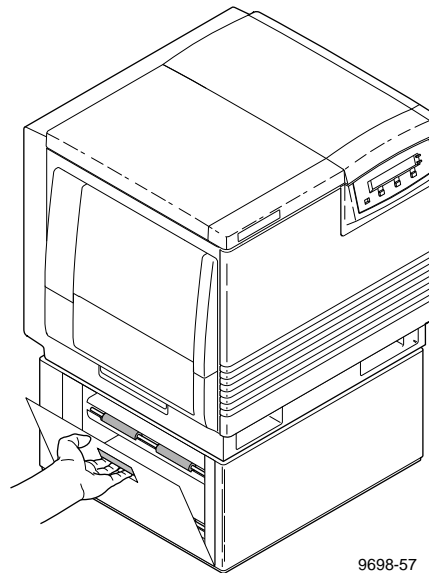

9698-57

2. Gently rotate the D-shaped paper-pick rollers 180°; wipe them with an alcohol-moistened lint-free cloth.

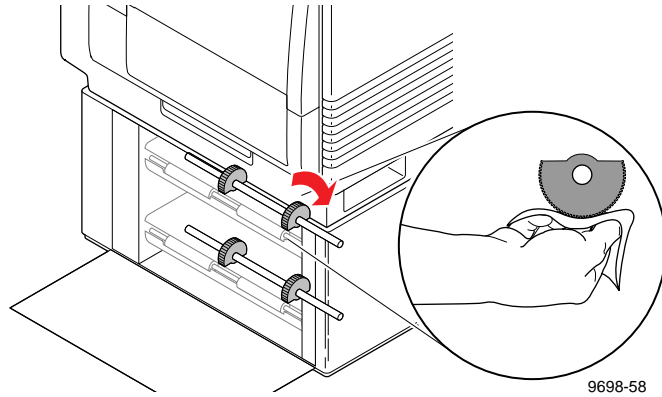

3. Clean the paper-feed rollers for the middle and lower media slots. Rotate each roller to clean its entire surface.

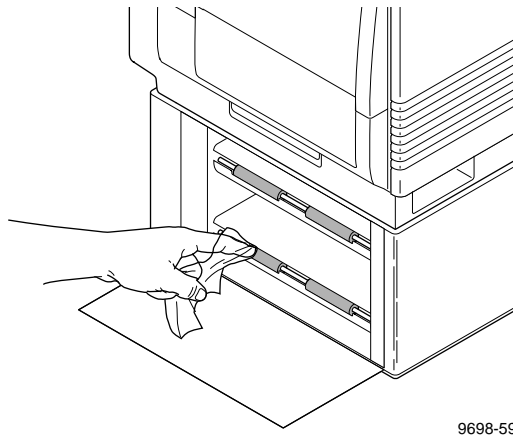

4. Close the lower left side door.
5. Insert the middle and lower media trays.

Cleaning other rollers

When you clean any of the other rollers in the printer, always use a lint-free cloth.

Caution *Do not clean the transfer roller; alcohol and pressing on the roller can damage the roller and cause print-quality problems.*

Cleaning the sensor

If your printer's front panel displays **Printer Error 30** clean the sensor inside the printer.

1. Turn the printer *off* and open the printer's front door.
2. Remove the Imaging Unit:
 - a. Loosen the two thumbscrews by turning them *counterclockwise*.
 - b. Turn the lower lever 180° *counterclockwise*.
 - c. Slide the Imaging Unit out of the printer and cover it to protect it from light exposure.

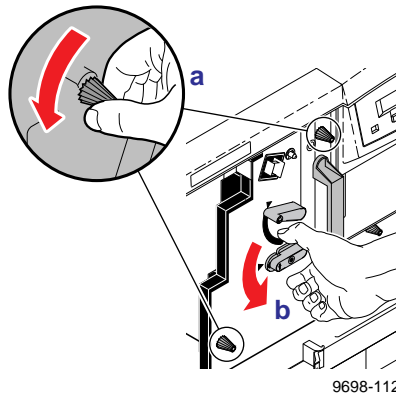

3. Use a *dry, lint-free cloth* to wipe the sensor (*inside the slot*).

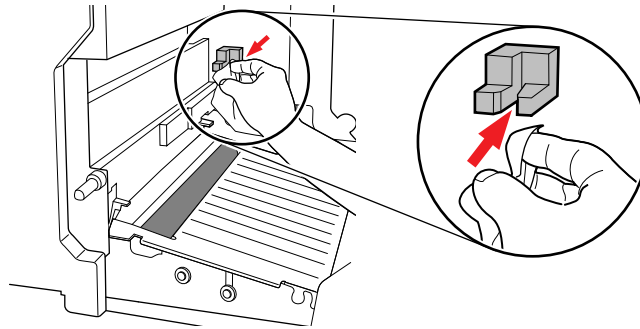

9698-64

4. Re-insert the Imaging Unit.
5. Close the printer's front door and power up the printer. You must cycle the power to clear the front panel's error message.

Repacking the printer

Power off

Turn off the printer; remove the power cord and all interface cables.

Prepare the media tray(s)

1. Remove the media tray(s) (A, B, C) from the printer; remove the media from the tray(s).

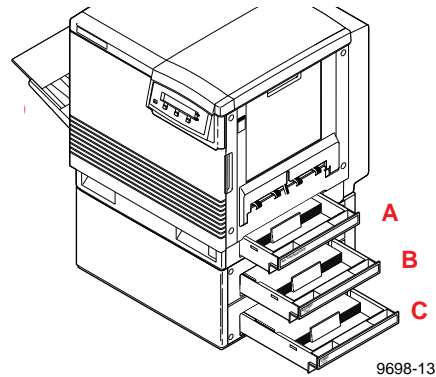

2. Press down on the media tray's metal plate.
3. Insert the cardboard packing material into the media tray.

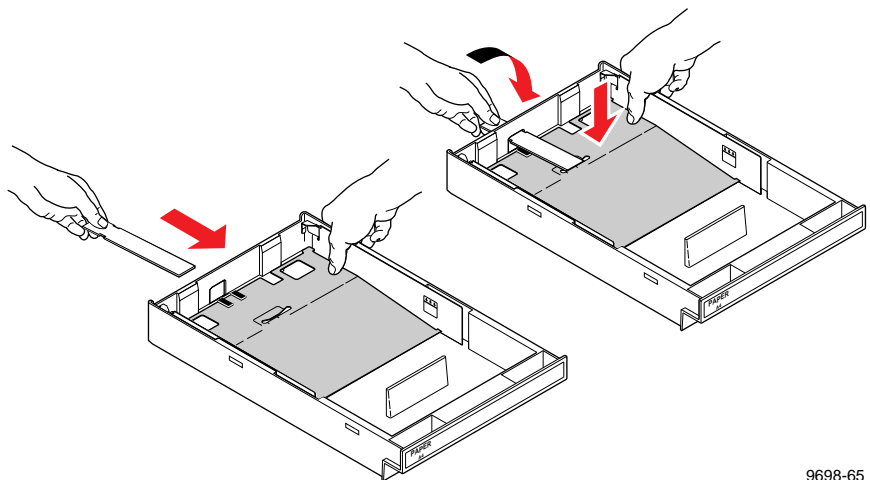

4. Re-insert the media tray into the printer.
5. If you have other media trays, repack them for shipping or storage in their original shipping boxes.

Remove and discard the Transfer Kit

1. Open the printer's left side door; use the blue handles to pull out the paper feeder.
2. Lift the cover of the paper feeder. Remove the transfer roller/waste bin; place it on a piece of paper on a flat surface.
3. Lock the roller onto the waste bin:
 - a. Placing a piece of paper over the roller and pressing down until it snaps tight.
 - b. Rotate the handles *down* to lock the roller in place.

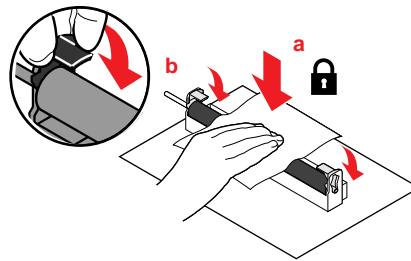

9698-114

4. Dispose of the old Transfer Kit as normal office waste.
5. Wipe off any loose toner in and around the printer.

Note *If a toner vacuum is available, it is the best tool for cleaning spilled toner. Do not use a standard office vacuum; the toner will not be retained by typical vacuum dust collectors.*

Prepare the Imaging Unit

1. Open the printer's front door.
2. On the Imaging Unit, turn the upper lever 90° *counterclockwise*; this is necessary to protect the Imaging Unit during shipment.
3. The two thumbscrews on the Imaging Unit should already be tightened; if they are not, turn them *clockwise* until they are tight.

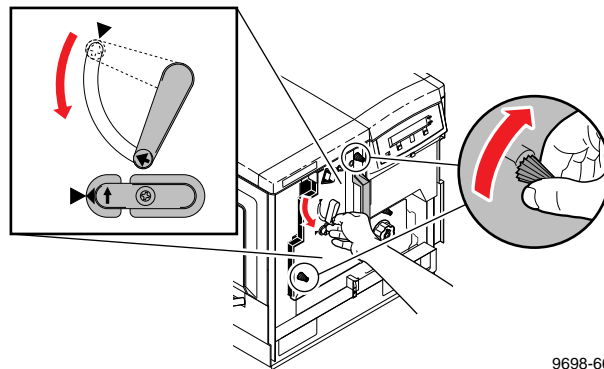

9698-66

Remove the toner cartridges

1. Open the right side door and remove the four toner cartridges.
2. Wipe off any loose toner in and around the printer.

Caution *Make sure that you leave the side door open for a minimum amount of time; light exposure can damage the Imaging Unit.*

3. Replace the protective cover for each toner cartridge; repack them for shipping or storage in their original shipping boxes.

Secure the doors and output tray

1. Close all printer doors and secure them with adhesive tape.
2. Raise the output tray and secure it to the printer with adhesive tape.

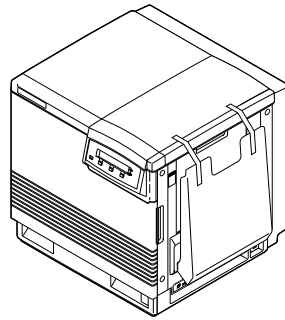

9698-67

If you don't have a Lower Tray Assembly, go to "Repack the printer" on page 6-23.

If you have a Lower Tray Assembly

1. Lift the printer up and away from the Lower Tray Assembly.

Warning *The printer weighs about 43 kg. (94 lbs.) without the toner cartridges; the Lower Tray Assembly weighs 14 kg (31 lbs.). Observe standard precautions for lifting heavy objects.*

2. Repack the Lower Tray Assembly in its original shipping box.

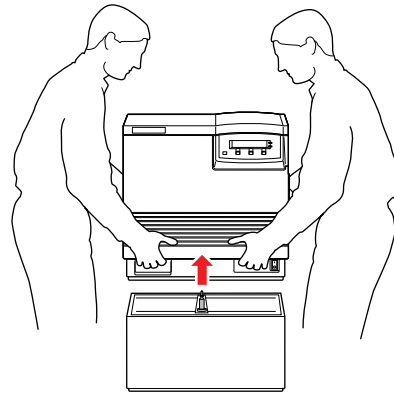

9698-69

Repack the printer

1. Repack the accessories in the original Tektronix accessories box.
2. Repack the printer and the accessories box in the original Tektronix shipping box. Call Tektronix at 1-800-835-6100 or call your nearest Tektronix dealer if you need a replacement packaging kit (order number 065-0566-00).

Caution *Make sure that you keep the printer level when moving it.*

Returning the printer to Tektronix

- To keep your printer's warranty valid, you *must* first remove the toner cartridges, remove and discard the Transfer Kit (transfer roller and waste bin), and tighten the Imaging Unit's lower lever and thumbscrews.
- Call Tektronix at 1-800-835-6100 or your nearest Tektronix dealer for a Return Authorization Number (RMA#).
- Write the RMA number on a sheet of paper and affix the paper to the printer with adhesive tape.
- Repack the printer in its Tektronix shipping box with the appropriate packing materials.
- Write the RMA number on the outside of the shipping box.

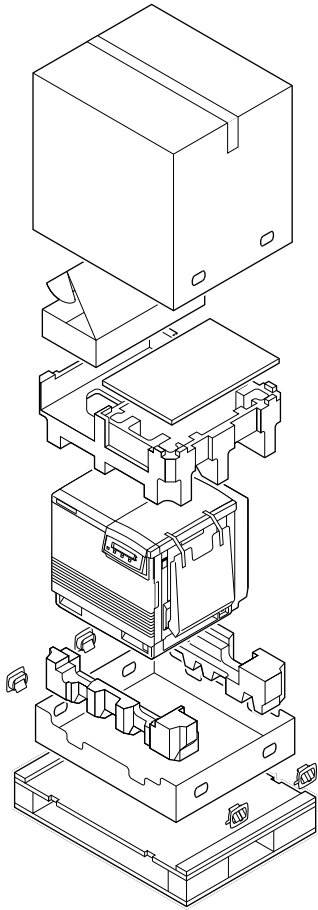

9698-68

Troubleshooting

If you need help

If you need assistance, contact your local Tektronix dealer or sales representative or any of these listed resources:

Type of service	How to access	Details	
Customer Support Centers Printer support and service	U. S. and Canada 1-800-835-6100	Monday through Friday 6:00 am to 5:00 pm PST	
	Australia 1800 811 177	Italy 1678 77261	
	Austria 0 660 5804	Luxembourg 0800 2853	
	Belgium 0800 1 5059	Norway 800 11782	
	Denmark 80 01 81 76	Spain 900 97 4499	
	Eastern Europe and the Middle East +44 1908 681707	Sweden 020 795 177	
	Finland 0800 1 14494	Switzerland 155 9493	
	France 05 90 85 41	The Netherlands 06 0221647	
	Germany 0130 82 10 68	UK 0800 558668	
	Supplies Information on local Tektronix dealers	U. S. 1-800-835-6100 Outside U. S. and Canada Contact local Tektronix dealers or offices for a list of local dealers	Canada 1-800-563-1289

7 Troubleshooting

Type of service (cont'd.)	How to access (cont'd.)	Details (cont'd.)
Tektronix Bulletin Board Service (BBS)	(503) 685-4504	24 hours per day, 7 days per week
Online services		
Technical support:	www.tek.com/Color_Printers/support/colcare.html	
World Wide Web:	www.tek.com/Color_Printers/	
Current software:	www.tek.com/Color_Printers/support/software.html	
Anonymous ftp server:	ftp.tek.com/Color_Printers	
HAL automated fax system	(503) 682-7450 direct outside U. S., Canada 1-800-835-6100 toll-free for U. S., Canada	24 hours per day, 7 days per week
EuroHAL automated fax system	Refer to "Using the automated fax systems" in this manual.	24 hours per day, 7 days per week
OzHAL automated fax system (Australia)	02 9878 0332, or 1-800-650-633 toll-free	24 hours per day, 7 days per week
Email update notices	World Wide Web: www.tek.com/Color_Printers/cgi-bin/mailS.pl	

Receiving email update notices

Using the World Wide Web, you can register to receive email notification of new printer drivers, accessories and upgrades for your Tektronix Phaser color printer as they become available. To subscribe to this free service, simply follow these steps:

1. Point your browser to the Tektronix web site:

http://www.tek.com/Color_Printers/cgi-bin/mailS.pl

2. Enter your email address and select your model of Phaser Color Printer from the pull-down list.
3. Click the subscribe button.

Using the automated fax systems

As an alternative to other resources, and to provide up-to-date information quickly, Tektronix has set up HAL (Highly Automated Library) and EuroHAL, two interactive, automated fax systems. These automated fax systems provide Macintosh, PC, and workstation users with the latest technical hints and tips (like color adjustments), solutions to common technical problems, and application notes for software problems (such as CorelDRAW! and QuarkXPress).

If you have a fax machine and a touch-tone voice telephone, you can order a HAL catalog, listing all of the information offered by HAL. You may call HAL or EuroHAL from anywhere in the world. The fax systems are available 24 hours a day, seven days a week.

Use EuroHAL to order a catalog or individual documents in Europe

EuroHAL includes many documents, some in English and some in other European languages. If a local version of the document you want is available, EuroHAL will send it in your language. Otherwise, it will send English documents.

Country	Numbers
Austria	
Belgium	
Denmark	00 44 1908 681839
Finland	
Holland	
Italy	
Norway	
Switzerland	
France	0800 90 81 86
Germany	0130 819 220
Spain	07 44 1908 681839
Sweden	009 44 1908 681839
UK	01908 681839
Other countries	+44 1908 681839 (where + is your country's International Access Code)

Symptoms and solutions

Diagnostic tools

The printer provides several tools for diagnosing and solving various types of problems; these tools include the following:

Consumables Page



Found in the **Help Pages** menu (accessed from the front panel); these help you diagnose print quality problems, for example, if a user-replaceable component, such as a toner cartridge, needs to be replaced.

Included on the Consumables Page is the **% Remaining** gauges, showing the approximate remaining life for the toner cartridges, Imaging Unit, Fuser, Fuser Roll, and Transfer Kit.

Configuration Page



Found in the **Help Pages** menu (accessed from the front panel). This page provides useful information for installation and troubleshooting.

Included on the Configuration Page is the **Copy Count** for each of the consumables.

PhaserLink



Allows you to use a standard web browser to view printer status, control printer configuration, view consumable information, and link to online documentation via the World Wide Web.

Note To use PhaserLink software, the printer must be connected to a network running TCP/IP. Refer to *PhaserShare Status Software User Manual* for complete details.

Front panel status messages and Info Button

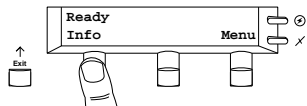

Automatically appear to reflect a condition requiring user intervention.

The **Consumables Report** menu provides **% Remaining** information on the consumables.

The **Info** button provides useful diagnostic information (suggestions and brief explanations) when the printer experiences a problem.

Troubleshooting / print quality quick reference table

Describes printing problems by symptom (including an example), then lists the possible causes and solutions. Especially useful for determining when the consumables need to be replaced. See page 7-7.

Quick Reference Guide



Provides easy access to troubleshooting information on media jams and maintaining print quality (including color examples of print quality symptoms).

Color Density Samples

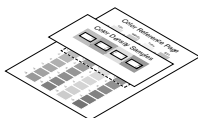

Provides samples of standard color density that you can compare to the printer's current settings that appear on the Color Reference Page. Stored inside the *Quick Reference Guide*.

Color Reference Page

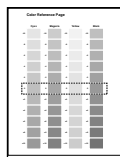

Found in the **Calibrate Colors** menu (accessed from the front panel). This page shows the printer's current density settings and the ranges for adjustment. Use this page to compare the printer's current settings to the examples in the color density samples. Refer to "Controlling color density" on page 5-2 for details.

PS Error Handler

Enabled in the **Printer Defaults** menu of the front panel. Used to diagnose PostScript problems. When a PostScript error occurs, an error page prints out if the error handler is enabled.

Maintaining print quality

If you notice a problem with the quality of your prints, the probable solution is replacing one of the consumable components (toner cartridges, Imaging Unit, Fuser, Fuser Roll or Transfer Kit).

- Make sure that you are using the recommended media. Refer to “Media hints and tips” on page 7-38 and “All about media” on page 4-30.
- Check if the printer’s front panel message indicates replacing one or more consumables and replace it if necessary.
- To help you diagnose the problem (in the absence of a front panel message), print the Consumables Page or Service Print 1 from the **Help Pages** menu in the front panel.
 - Use the Consumables Page and Service Print 1 to diagnose and correct any print quality problems. If you need to call the Customer Support Hotline, always print the Consumables Page first; it contains useful diagnostic information.
 - Refer to the table “Troubleshooting and print quality quick reference” on page 7-7 for examples of symptoms, probable causes, and solutions. The *Phaser 560 Color Laser Printer Quick Reference Guide* and the CD-ROM and World Wide Web topics contain color examples of some of the most common print artifacts to help diagnose and correct print quality problems.

From the Help Pages menu in the front panel, select **Consumables Page**

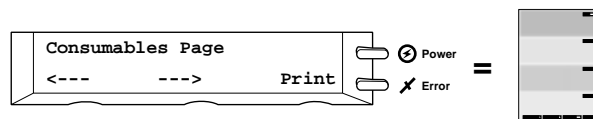

From the Help Pages menu in the front panel, select **Service Print 1**

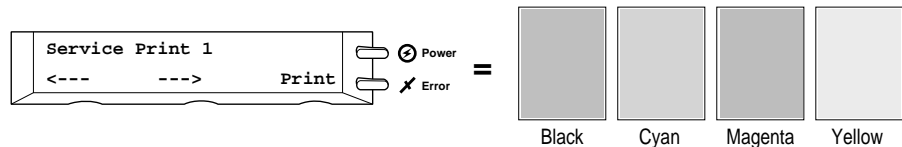

9698-30

Troubleshooting and print quality quick reference



Symptom	Possible Causes	Solution
Power indicator is blinking	The printer is receiving, processing or printing a job.	Wait for the job to be completed or cancel the job.
	You have entered the menu in the front panel.	Exit the menu.
Power indicator is off	The printer is not ready, is disabled, or has detected an error.	Read the front panel message to determine the printer's status.
Error indicator is on	Attention is required, but not immediately. For example, when the front panel reads <color>:low	Correct the condition reported by the front panel.
Error indicator is blinking	The printer is stopped because it detected a user-correctable error such as an open door or a media jam.	Correct the condition reported by the front panel (e.g., close the door or clear the media jam).
	Error occurred that may be user-correctable.	Press the InfoMore button for more information on the error condition.
	Error occurred that is not user-correctable.	Turn the printer off and back on again. If the indicator is still on after the power-up sequence, the printer requires service. See page 7-1.
The front panel menu exits and returns to Ready without anyone pressing the button.	Front panel timeout: if no activity occurs in 5 minutes, the front panel returns to Ready .	Press Menu to enter the front panel menu.
Front panel reports: Jam at <Location>: See inside front door	Media jam.	<ul style="list-style-type: none"> ■ To find the jam: refer to the paper path illustration on the inside front door label or refer to "Clearing a media jam" on page 7-39. ■ To clear the jam: refer to the instructions in this chapter or in the <i>Quick Reference Guide</i>. ■ Make sure that paper or transparencies are installed correctly and in the media-specific tray. See page 2-12.
	Too much media is loaded in the media tray.	Reduce the amount of media to below the media level indicator on the media tray label.
	Media is wrinkled or curled.	Change the media.
	Media is too thick or too thin.	Use recommended media. Refer to page 7-38 for more information. For media loaded in the Multi-Purpose Feeder, make sure that you have set the Media Thickness switch on the printer to accommodate thick, medium, or thin media.

Troubleshooting and print quality quick reference (cont'd.)

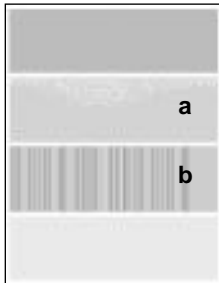
Symptom	Possible Causes	Solution
Front panel reports: Waiting for <media>	The media installed is not what the printer is expecting.	<ul style="list-style-type: none"> ■ Insert the appropriate media tray. ■ Change the default media tray to match the desired media type; restart the printer. ■ Cancel the job and check for the appropriate driver selection. ■ If the message persists, call the Customer Support Hotline.
Front panel reports: Multi-Purpose Feeder: Load <media>		<ul style="list-style-type: none"> ■ Load the indicated media type in the Multi-Purpose Feeder.
Front panel reports: <color>:low	The indicated color toner cartridge is almost empty.	<ul style="list-style-type: none"> ■ Change the toner cartridge soon.
Front panel reports: Stopped: replace <color>	Indicated color toner cartridge is empty.	Replace the indicated color toner cartridge now ; the printer stops until you replace the cartridge.
Consumables Page shows a single color (a) that is not uniform <i>or</i> Consumables Page shows a single color (b) with many vertical streaks (both light and dark) of slightly different density and non-uniform color.	The toner cartridge is nearly empty.	Replace the color toner cartridge.

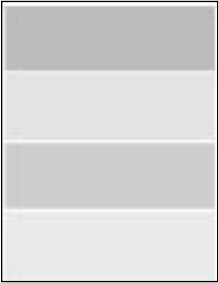
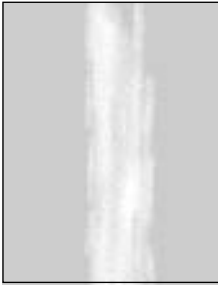

Troubleshooting and print quality quick reference (cont'd.)



Symptom	Possible Causes	Solution
<p>Consumables Page appears faded in a single color.</p> 	<p>The color density is set incorrectly in the front panel.</p> <p><i>or</i></p> <p>The toner cartridge is wearing out.</p>	<p>Check the density setting by printing the Color Reference Page in the Calibrate Color menu in the front panel. Compare the settings to the examples on the <i>Color Density Samples</i> and, if necessary, adjust the density in the front panel. Refer to "Controlling color density" on page 5-2.</p> <p>Replace the color toner cartridge soon (depending on the complexity of your prints, you can continue to print up to 100 more pages).</p>
<p>A single color has a wide, light, vertical streak.</p> 	<p>Toner cartridge is depleted.</p>	<p>Replace the color toner cartridge.</p>
<p>Service Print 1 shows small, repeating light or dark spots in a single color.</p> 	<p>The color toner cartridge is damaged.</p>	<p>Replace the color toner cartridge.</p>

7 Troubleshooting

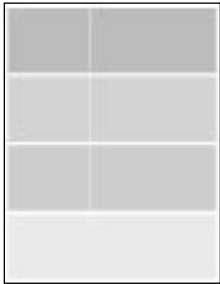
Troubleshooting and print quality quick reference (cont'd.)

Symptom	Possible Causes	Solution
<p>A single color shows a light, repeating horizontal line.</p> 	<p>The roller in the toner cartridge has a slight impression after long storage.</p>	<p>To fix the problem:</p> <ul style="list-style-type: none">■ Run 20-30 prints. The impression will disappear with continued time and use. <p>To avoid the problem:</p> <ul style="list-style-type: none">■ Occasionally, or a day or two before installing a new toner cartridge, rotate the gear on the end of the cartridge by at least a quarter turn.
<p>Front panel reports: Imaging unit:replace</p>	<p>The Imaging Unit is wearing out.</p>	<p>Replace the Imaging Unit soon.</p>
<p>Front panel reports: Imaging unit expired</p>	<p>The Imaging Unit is worn out.</p>	<p>Replace the Imaging Unit now; although it continues to function, the print quality is affected.</p>
<p>Prints are missing fine-line detail.</p>	<p>The Imaging Unit is worn out.</p>	<p>Replace the Imaging Unit.</p>
<p>Dark color spots and dark or light streaks appear in all colors.</p>	<p>The Imaging Unit is worn out.</p>	<p>Replace the Imaging Unit.</p>
<p>Consumables Page shows a straight, thin and even, light vertical line in all colors.</p> 	<p>The photosensitive belt inside the Imaging Unit is scratched.</p>	<p>Replace the Imaging Unit.</p>

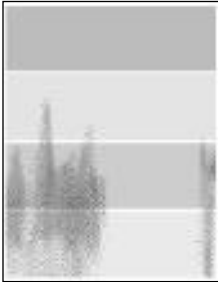
Troubleshooting and print quality quick reference (cont'd.)

Symptom	Possible Causes	Solution
<p>On the Consumables Page, each color “bleeds” into the color band below it (the most visible is magenta in the yellow band).</p> 	<p>The Imaging Unit's internal waste toner box is full.</p>	<p>Replace the Imaging Unit.</p>
<p>A single white spot appears in approximately the same vertical place on the page.</p> 	<p>The Imaging Unit is damaged.</p>	<p>Replace the Imaging Unit.</p>
<p>A single, wide, light horizontal band appears in one place on the page (near the top) or all colors are faded.</p> 	<p>The Imaging Unit was exposed too long to light.</p>	<p>Wait overnight and print the Consumables Page. If print quality hasn't changed, replace the Imaging Unit.</p>

7 Troubleshooting

Troubleshooting and print quality quick reference (cont'd.)

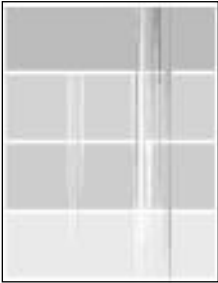
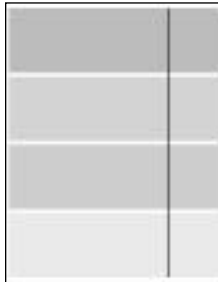
Symptom	Possible Causes	Solution
<p>Large light spot(s) appear randomly in the Consumables Page, approximately on the same horizontal and vertical place or they move vertically from one print to another.</p> 	<p>Fingerprint(s): someone has touched the underside of the Imaging Unit.</p>	<p>Print several pages until the artifacts fade.</p>
<p>A smear in the image repeats at the same location on the page .</p> 	<p>A label from a sheet of labels has peeled off and stuck inside the Imaging Unit.</p>	<p>Replace the Imaging Unit.</p>
<p>One or more vertical, dark and even fine lines appear on the print through all colors.</p> 	<p>The Imaging Unit is scratched. or The Fuser is damaged.</p>	<p>Replace the Imaging Unit; make sure that the old Imaging Unit is not exposed to light for more than 3 minutes.</p> <p>If a new Imaging Unit does not correct the problem:</p> <ul style="list-style-type: none">■ Put the old Imaging Unit back into the printer.■ Repack the new Imaging Unit.■ Replace the Fuser.

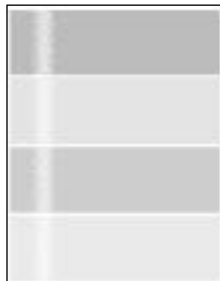

Troubleshooting and print quality quick reference (cont'd.)

Symptom	Possible Causes	Solution
Front panel reports: Fuser:replace	The Fuser is wearing out.	Replace the Fuser soon.
Front panel reports: Fuser expired	The Fuser is worn out.	Replace the Fuser now ; although it continues to function, the print quality is affected.
A piece of the printed image is missing and reappears out of place, approximately 129 mm (5 in.) down the page.	The Fuser's internal roller is not being consistently oiled. or The Fuser's internal roller is contaminated with toner particles.	<ul style="list-style-type: none"> ■ Print 5-10 pages of blank pages to clean the roller. If you still see the problem: <ul style="list-style-type: none"> ■ Replace the Fuser Roll. If you still see the problem: <ul style="list-style-type: none"> ■ Replace the Fuser.
The surface of the printed image appears to have vertical scratches (visible by holding the print at an angle and observing the "shine" of the image). At first, the scratches appear only on the printed image; eventually, dark vertical scratches appear on the unprinted portion of the page.	The Fuser is wearing out.	Replace the Fuser (depending on your quality needs, you can continue to print until the dark vertical lines appear).
A piece of the printed image is missing and reappears out of place, approximately 129 mm (5 in.) down on the page.	The Fuser's internal roller is not being consistently oiled. or The Fuser's internal roller is contaminated with toner particles.	<ul style="list-style-type: none"> ■ Print 5-10 pages of blank pages to clean the roller. If you still see the problem: <ul style="list-style-type: none"> ■ Replace the Fuser Roll. If you still see the problem: <ul style="list-style-type: none"> ■ Replace the Fuser.
Media frequently wraps around the Fuser.	The Fuser Roll is worn out.	<ul style="list-style-type: none"> ■ Replace the Fuser Roll.
Light vertical streaks appear in all colors (most easily visible in yellow).	The Main Charge Grid is dirty.	Replace the Main Charge Grid. Complete instructions are packaged with the Main Charge Grid. Refer to "Supplies and accessories" on page 9-2 for ordering information.

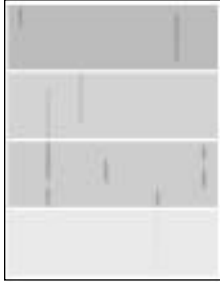

7 Troubleshooting

Troubleshooting and print quality quick reference (cont'd.)

Symptom	Possible Causes	Solution
<p>Dark and wavy vertical streaks appear in all colors (most easily visible in yellow).</p> 	<p>The Main Charge Grid is dirty.</p>	<p>Replace the Main Charge Grid. Complete instructions are packaged with the Main Charge Grid. Refer to "Supplies and accessories" on page 9-2 for ordering information.</p>
<p>The entire page prints in black, including the borders.</p> 	<p>The cause is one of the following:</p> <hr/> <p>Bad electrical contact for the Main Charge Grid.</p> <hr/> <p>The Main Charge Grid is broken.</p> <hr/> <p>Power supply high voltage.</p>	<p>The solution is one of the following:</p> <ul style="list-style-type: none"> ■ Re-insert the Imaging Unit to correct the contact for the Main Charge Grid. ■ Replace the Main Charge Grid with a new one. ■ Call Service. See page 7-1.
<p>Front panel reports: Transfer Kit:replace</p>	<p>The Transfer Kit is worn out.</p>	<p>Replace the Transfer Kit.</p>
<p>Toner spots appear on the back of the media.</p>	<p>The Transfer Kit is worn out.</p>	<p>Replace the Transfer Kit.</p>

Troubleshooting and print quality quick reference (cont'd.)

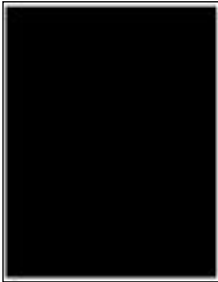
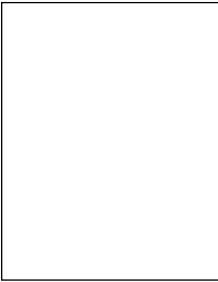
Symptom	Possible Causes	Solution
<p>The page prints in black in the image area only (the borders are clear).</p> 	<p>Either the image processor board or engine control board is not functioning properly.</p>	<p>Turn the printer off and back on again. If the problem persists, call Service. See page 7-1.</p>
<p>The page is completely blank.</p> 	<p>The problem could be with one of the following:</p> <ul style="list-style-type: none"> ■ Engine control board. ■ Developer voltage. ■ Laser scanning unit mirror. 	<p>Turn the printer off and back on again. If the problem persists, call Service. See page 7-1.</p>
<p>Front panel reports: Printer Error ##</p>	<p>An error occurred that is not user-correctable.</p>	<p>Press the Info button on the front panel for more information on the problem. Press the button labeled More for suggestions on correcting the problem.</p> <p>Turn the printer off and back on again. If the error persists, call Service. See page 7-1.</p>
<p>Thin horizontal stripes or a "weave" pattern appears in a complex image.</p>	<p>The printer has insufficient memory for an image of this complexity.</p>	<p>Increase the amount of memory. Refer to "Memory upgrade" on page 9-7.</p> <p>or</p> <p>Print the image at a lower resolution.</p>

If you can't make a print

Symptom	Solution
Printer not operating	Make sure that you plugged in the printer and turned it on.
	Make sure that you connected the interface cable(s) properly.
	Print the Consumables Page from the front panel to verify that the controller board is functional.
	Verify that your print engine is functional by pressing the Test Print button (the blue pushbutton in the center of the back of the printer), and holding it down for 3 seconds.
	Verify that your printer can communicate:
	<p>If you have a Macintosh Make sure that you have the correct PPD file installed and selected and that you have selected the printer in the Chooser. If the printer's name does not appear in the Chooser, your LocalTalk, EtherTalk, or TokenTalk connection may be faulty. (See also "Printer doesn't appear in the Chooser (Macintosh)" on page 7-16.)</p> <p>You can use the Print Window command to send a file to the printer without using an application. If the communication link between your computer and the printer is working, the printer produces a directory listing of the active window on the desktop.</p> <p>If you have a PC Type this DOS command:</p> <pre>echo %! > port echo showpage[Ctrl-D] > port</pre> <p>Where [CTRL-D] indicates pressing the D key while holding down the CTRL key. Substitute the name of the printer port (for example COM1:, COM2:, LPT1:, LPT2:) for the variable <i>port</i> in this command. For example, if you are testing a parallel connection on LPT1, type:</p> <pre>echo %! > lpt1: echo showpage[Ctrl-D] > lpt1:</pre> <p>If the communication link between your computer and the printer is working, the printer ejects a blank page. If this occurs, but you cannot print from your application or through Windows, make sure that the appropriate driver is installed and that you have selected the printer correctly.</p>
Printer doesn't appear in the Chooser (Macintosh)	Make sure that the printer is turned on and the cables are correctly attached.
	Check the termination (refer to the documentation for your network adapter or connector for information on termination).
	If you have changed the printer's name, make sure that you have given it a unique name (not the same as any other printer in the zone or on the network).
	Make sure that the correct network is selected in the Network Control Panel.

If you can't make a print (cont'd.)

Symptom	Solution
Power indicator blinks and stops, but the file does not print	This is probably the result of a PostScript error. Enable the PostScript error handler in the printer's front panel. For more information on using the PostScript error handler, refer to the topics on the printer's CD-ROM or the Tektronix World Wide Web site.
Printer will not power up to Ready	This may be the result of an unterminated network connection. The printer sees network activity, but is unable to successfully connect.
Print job does not finish (the printer times out)	<p>If you are using the serial or parallel port from a PC, make sure that you used the MODE command to set the PC's communication parameters. For example:</p> <p style="text-align: center;">MODE LPT1:,,P > NUL</p> <p style="text-align: center;">MODE COM1:9600,N,8,1,P</p> <p>The P parameter in these commands sets the port timeout to Infinite Retry and must be part of the command.</p> <p>If you are using Windows 3.1, make sure that the Transmission Retry value for the printer's assigned port is set to 900. For more information, see page 4-11 or page 7-28.</p>
Error indicator is blinking	<p>The Error indicator blinks with any hard error, such as media jam, door open, or a missing component.</p> <p>Look at the front panel for an indication of the type of error. The Info button provides more details on the type of error, as well as brief suggestions for correcting the problem (for example, Reset Fuser). Follow the instructions under this button.</p> <p>If the error condition cannot be fixed with user interaction, turn the printer off and on again. If the Error indicator remains on after power-up, your printer requires service. See "If you need help" on page 7-1 for telephone information.</p>

Media problems

Symptom	Solution
Frequent paper-picking errors	<p>Make sure that the Media Thickness switch is set correctly for the media installed in the Multi-Purpose Feeder. Refer to "Setting media thickness" on page 4-41 for more information. If the printer picks multiple sheets of paper at once, set the Media Thickness switch to a thinner setting.</p> <p>Fan the paper or transparencies before installing them in their respective trays; this is especially important for transparencies because they tend to stick together.</p> <p>Make sure that the media is installed under the hooks at the front of the media tray.</p> <p>If printing on transparencies and your printer has a Lower Tray Assembly, make sure that the TRANSPARENCY tray is installed in the Upper or Middle tray slot.</p> <p>Clean the paper-feed rollers and paper-pick rollers. See page 6-12 for instructions.</p>

Media problems (cont'd.)

Symptom	Solution
Frequent media jams	Make sure that you use a high-quality laser paper: 75-105 g/m ² (20-28 lb.) paper in the media trays and 75-120 g/m ² (20-32 lb.) paper in the Multi-Purpose Feeder. Refer to "Media hints and tips" on page 7-38 for more information.
	Make sure that the Media Thickness switch is set correctly for the media installed in the Multi-Purpose Feeder. If the printer has frequent paper jams, set the Media Thickness switch to a thicker setting. Refer to "Setting media thickness" on page 4-41 for more information.
	If you are using media that is 120 g/m ² (28 lb.), check if the Face Down media output setting is selected in the driver. If it is, change the setting to Face Up . If the problem persists, use the Multi-Purpose Feeder rather than a media tray.
	Use only Tektronix transparencies that are listed on the supplies information sheet. Tektronix does not guarantee the results of non-Tektronix transparencies in Tektronix printers.
	Make sure that the media is installed under the hooks at the front of the media tray.
	Do not overfill the media tray, as indicated by the red line on the right side of the tray.
	Clean the paper-feed rollers and paper-pick rollers. See page 6-12 for instructions.

Problems with image size and position

Symptom	Solution
Off-set images	Check your application for correct image sizing.
Cut-off images	Check your application for image sizing.
	Make sure that you are using a Phaser 560 printer PPD file and have selected the correct page size.
	Make sure that the correct size media is in the media tray.
Image shifts or margins are incorrect (Macintosh)	Make sure that you have installed the Phaser 560 printer driver, the Phaser 560 GX printer driver, or the correct PPD file onto your Macintosh so that you can select the correct page sizes from the driver. For details on the driver, refer to the topics on the printer's CD-ROM or the Tektronix World Wide Web site. For details on how to print from a Macintosh, refer to "Printing from a Macintosh" on page 4-12.
	If printing on transparencies and you have a Lower Tray Assembly installed, make sure that the TRANSPARENCY tray is installed in the Upper or Middle tray slot.

Print quality problems

Symptom	Solution
Prints have dull, faded colors	<ul style="list-style-type: none"> ■ If you are using a media tray, make sure that you have loaded the correct media in the PAPER tray or TRANSPARENCY tray. ■ If you are using the Multi-Purpose Feeder, make sure that you have selected the correct media type in the printer's front panel or in the printer driver.
	Print the Color Reference Page from the Calibrate Colors menu in the front panel. Check the density settings for each color and compare them to the examples on the <i>Color Density Samples</i> card. Refer to "Controlling color density" on page 5-2 for instructions on comparing and setting color density.
	Print the Consumables Page from the Help Pages in the front panel.
	<ul style="list-style-type: none"> ■ If all colors are faded, the Imaging Unit may need to be replaced. Refer to the % Remaining gauge for the Imaging Unit at the bottom of the Consumables Page. ■ If one color is faded (and you have checked and/or adjusted the density setting for that color), replace the toner cartridge.
	Make sure that the Imaging Unit stays covered until immediately before installing it in the printer. Exposure to light can damage the Imaging Unit and will produce light streaks or faded prints.
	Make sure that the toner cartridges are installed correctly.
	Make sure that you use a high-quality laser paper: 75-105 g/m ² (20-28 lb.) paper in the media trays and 75-120 g/m ² (20-32 lb.) paper with the Multi-Purpose Feeder. Refer to "Media hints and tips" on page 7-38 and to page 9-2 for ordering information.
Image is very faded or pieces of the image are missing; toner on the page is loose.	Use only Tektronix transparencies that are listed in "Supplies and accessories" on page 9-2. Tektronix does not guarantee the results of non-Tektronix transparencies in Tektronix printers.
	Try a different color correction mode.
Photographic images appear grainy	When using the Multi-Purpose Feeder, make sure that you have selected the correct media type in the driver or the printer's front panel menu.
	<p>Check the Print Quality menu in the front panel. If the selected mode is Presentation, change it to Standard.</p> <p>The Presentation print-quality selection in the front panel substitutes Presentation mode rendering when Standard mode is selected in the driver.</p>

Print quality problems (cont'd.)

Symptom	Solution
Streaks or spots	<p>Most spots are caused by fingerprints or dust introduced into the printer while installing the Imaging Unit or loading media.</p> <p>Make sure that the surface where you unpack the Imaging Unit, paper, and transparencies is free of dust. Keep supplies in a covered area or a closed box.</p> <p>Make sure that the Imaging Unit stays covered until immediately before installing it in the printer. Exposure to light for more than 3 minutes can damage the Imaging Unit.</p> <p>Do not touch the right side or underside of the Imaging Unit; fingerprints affect print quality.</p> <p>Make sure that the media is clean.</p> <p>Make sure that you handle the media on the outside edges to avoid fingerprints.</p> <p>To get rid of fingerprint spots, print a few prints (you can print any of the Help Pages in the front panel menu).</p>
The back of the printed page appears dirty.	<p>Toner particles have contaminated the transfer roller. This can happen if the printed image is larger than the media (for example, when printing on envelopes). Run 10-20 prints to clean the transfer roller.</p>
Black-and-white prints instead of color	<p>If you have a Macintosh Make sure that you are using the Phaser 560 printer driver, the Phaser 560 GX printer driver, or the correct PPD file with the latest Apple LaserWriter printer driver (version 6.0.7 or higher), which supports color PostScript.</p> <p>Make sure that Color/Grayscale is selected in the Print dialog box. Some applications require special files to print in color. Make sure that these files are properly installed. For information, refer to the topics on the printer's CD-ROM or the Tektronix World Wide Web site.</p> <p>Make sure that you have not selected Fast Monochrome in the Print-Quality dialog box.</p> <p>If you have a PC Be sure to use a driver that supports color PostScript. If you are using Windows 3.1, use the Phaser 560 printer driver.</p> <p>If you are using Windows, make sure that the Color box in the Options dialog box is checked. For information on the drivers, refer to the printer's CD-ROM or World Wide Web topics.</p> <p>Make sure that you have not selected Fast Monochrome in the Tektronix Printer Features dialog box.</p> <p>If you are not using a driver, make sure that you have not set the monochrome mode selection code; make sure that the front panel is not set for Fast Monochrome</p>
Blue colors look too purple	<p>If printed blue colors look too purple, print your document with the Vivid Color color correction. Refer to "Color corrections" on page 4-24 or "Deciding which color correction to use" on page 5-18 for instructions and more information.</p>

Printing hints

Application hints

For information about using specific software applications with your printer, contact Tektronix' HAL or EuroHAL information systems. In the U.S., call 1-800-835-6100 or (503) 682-7450; for EuroHAL telephone numbers, refer to "If you need help" on page 7-1. For a complete listing of available topics, request a catalog.

Tektronix supplies and software

Always use Tektronix supplies to ensure the highest quality prints and printer performance. Do not use any media designed for inkjet printers, especially inkjet coated paper and inkjet transparencies. Inkjet media are coated with a substance that will damage the fuser; Tektronix does not furnish service for damage or malfunction caused by the use of non-Tektronix supplies or consumables. Always use Tektronix-brand coated paper and transparencies that have been specially designed for use with Tektronix Color Laser Printers.

Tektronix Printer Description Files (PPDs) and utility files work with the drivers to provide the best access to printer features. See page 9-2 for ordering information.

Getting the largest printed picture

To get the largest printed picture, keep in mind the following:

- The area of media that the Phaser 560 prints on is smaller than the size of the media (refer to "Margins and print area" on page 4-31 for more details). You may have to adjust the margins in your application software.

The correct-sized image for the media

- Make sure that the image you are printing is smaller than the size of the selected media (for example, when printing on envelopes).

Improving print speed

There are different ways to improve print speed, such as by upgrading to EtherTalk on a Macintosh, to Novell NetWare on a PC, or to TCP/IP on a workstation. For more information, request a document catalog from HAL or EuroHAL, the Tektronix automated fax systems. Refer to page 7-3 for instructions on using these systems.

Relative port speed

Ethernet and Token Ring are the fastest ports, followed by the parallel port, the LocalTalk port, then the serial port.

Fastest print time

The total print time depends on the following:

- Image complexity
- Image size
- Type of port used and network traffic
- Printer's memory configuration
- Print quality mode selected
- Color correction mode selected
- If Image Smoothing is activated
- Number of non-resident fonts used

Of these elements, only the time contributed by the printer's paper-marking speed (the time it takes the printer to put the toner on the paper once it has received the processed image) is predictable; the others can vary greatly depending on your system configuration and the type of image you are printing. However, the Phaser 560 printer's PostScript interpreter combines very fast image processing and communication with sophisticated memory management to keep the total print time to a minimum.

For the fastest printing speed, refer to "Using simple color conversions" on page 5-23.

The printer's optimum image processing throughput via a dedicated Ethernet connection is faster than the other ports. Actual throughput will generally be somewhat affected by network traffic, image complexity, color correction, and memory configuration. For details on the printer's paper-marking speed, see "Specifications" on page 10-7.

If you tried to print a document with bitmapped images, but are dissatisfied with the speed of the output, here are some suggestions.

All users

- When you use any color correction option (other than None), your printer can take longer to process bitmapped images. Select color corrections from the supported drivers, with downloadable utility files, or from the printer's front panel; see page 4-24 for instructions.
- The Fast Color print quality option prints faster than any of the other modes. Select print quality modes from the supported drivers, with downloadable utility files, or from the printer's front panel. See page 4-23 for details on the print quality modes.

Macintosh and Windows users

- If you are using Adobe Photoshop, you can print using the Tektronix PhaserPrint plug-in to improve the image data transfer time from your Macintosh to the printer. For instructions on installing and using the plug-in, refer to the printer's CD-ROM and World Wide Web topics.

Windows 3.1 users

(using the Tektronix driver)

1. From the Control Panel, double-click Printers.
2. Select the Tektronix Phaser 560 printer in the Printers dialog box.
3. Disable Use Print Manager in the Printers dialog box. Printing via the Print Manager is slower, but turning it off ties up the PC longer.
4. From the Printers dialog box, click Setup.
5. From the Setup dialog box, click Options.
6. From the Options dialog box, click Advanced.
7. Make sure that the Use PostScript Level 2 Features check box in the Advanced Options dialog box is turned on.
8. From your application, choose the Tektronix Phaser 560 as your printer.
9. Try printing the document again.

Windows 95 users

1. Click the Start icon in the taskbar on your screen; a menu appears.
2. Move the cursor over Settings; another menu appears.
3. In the menu, click Printers; the Printers window appears.
4. In the Printers window, select the Phaser 560 printer icon, then select Properties from the File menu.
5. Click the PostScript tab, then click the Advanced button.
6. Select Use PostScript Level 2 features.
7. Click OK when finished.
8. Try printing the document again.

UNIX workstation users

Workstation users can use the PhaserPrint for UNIX software to increase printer performance when printing bitmapped images. Refer to page 4-18 for details.

PostScript printing errors

Note For information on specific applications, request a document catalog from HAL or EuroHAL, the Tektronix automated fax systems. Refer to page 7-3 for instructions on using these systems.

If your printer reports a PostScript error when printing from Adobe PageMaker, Adobe FreeHand, QuarkXPress, or Canvas, you may be using an older or incorrect version of the Printer Description File (PPD). Refer to “Installing Printer Software” on page 3-1 for instructions on installing printer description files.

1. You should always use the most current printer description file. To determine the date of the file you are using, do the following:
 - **Macintosh users:**
Select (highlight) a printer description file and choose Get Info from the File menu. Make a note of the version date.
 - **Windows 3.1 users:**
Check a printer description file’s creation date in the File Manager. Make a note of the version date.
 - **Windows 95 users:**
Check a printer description file’s creation date in the Windows Explorer. Make a note of the version date.
2. Check the Tektronix World Wide Web site or the Tektronix Bulletin Board Service (BBS) to see if the printer description files you have are the most recent. Refer to page 7-1 for instructions.

Using a PostScript error handler

The error handling utility, enabled in the **Printer Defaults** menu of the printer's front panel, is useful for diagnosing problems when a job doesn't print. It provides a PostScript error-handling function to help determine the cause of some PostScript printing problems. PostScript errors are printed on a page with other status information when an error occurs. This utility can be useful to programmers and technical support for debugging PostScript code.

To turn the error handler on, follow these steps:

1. In the printer's front panel, press the **Menu** button.
2. Press the right or left arrow button until the front panel displays this message:

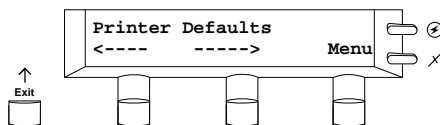

3. Press **Menu**.
4. Press the left arrow button; this message appears:

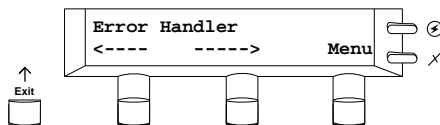

5. Press **Menu**. This message appears:

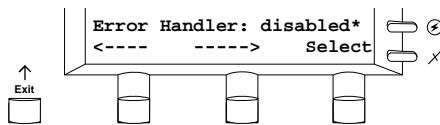

The * indicates the current selection; *disabled* is the factory default.

6. Press an arrow button. The front panel displays this message;

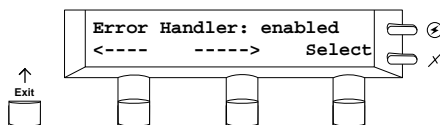

7. Press **Select**
8. Press the **Exit** button until the front panel reads **Ready**.

After turning on the error handler, resend the print job; the printer produces an error page.

Fixing timeout problems in Windows

Try one of the following procedures to correct Windows timeout problems. If a Windows procedure doesn't work for you, try the DOS procedure (refer to the on-line manual on the printer's CD-ROM or at Tektronix' World Wide Web site).

From Windows 3.1

1. Open the Control Panel from the Main menu.
2. Double-click the Printers icon to open the Printers dialog box.
3. Click the Connect button to open the Connect dialog box.
4. Increase the Transmission Retry to 840 seconds by typing in the new number.
5. Click OK.

From Windows 95

1. Click the Start icon in the taskbar on your screen; a menu appears.
2. Move the cursor over Settings; another menu appears.
3. In the menu, click Printers; the Printers window appears.
4. In the Printers window, select the Phaser 560 printer icon, then select Properties from the File menu.
5. Click the Details tab and increase the Transmission Retry to 950 seconds by typing in the new number.
6. Click OK.

Printed colors are not what you expected

In general

- Select another Color Correction option in a supported driver and print your image again; refer to page 4-24 for more information on color correction.
- If you are not using a supported driver and are sharing the printer with other users on a network, another user may have changed the printer's color adjustment setting. Refer to page 7-36 for more information on sharing a network printer.
- If you use the driver's Use Printer Setting option and printed colors are not what you expected, check the following:
 - Check the printer's color density settings in the front panel **Calibrate Colors** menu. You may need to adjust one or all of the colors. Refer to "Controlling color density" on page 5-2 for details.
 - A selection may have been made in the TekColor Correction menu on the printer's front panel. These settings change the printer's color correction setting.
 - A color correction utility file may have been downloaded to the printer. These files change the printer's color correction setting.

Refer to "Color correction descriptions" on page 5-20 for details on how these settings affect prints made from a driver.

Printing PANTONE Colors

If Phaser 560 printer-specific PANTONE Colors are not printing as expected, make sure that you are printing without any color corrections selected. Refer to “Printing and using the color sampler charts” on page 5-25 for more information.

If you have questions about PANTONE Color Matching, refer to the HAL article on PANTONE Colors. Refer to page 7-3 for information on using the HAL and EuroHAL fax systems.

There are many variables in process reproduction of colors generated by the Phaser 560 printer, any one of which may affect the quality of the PANTONE Color simulation, including:

- Type of media used
- Print quality mode selected
- Effective final resolution
- Dot structure/halftones
- Density of the toner colors.

Using the Tektronix halftone screens

Tektronix halftone screens are designed for Tektronix printers, and improve print quality over application-set halftone screens. The *Setscreen Off* (*SCRENOFF.PS*) utility file redefines some PostScript operators, such as the *setscreen*, *setcolorscreen* and *sethalftone*. When downloaded to the printer, this file prevents applications from overriding the Tektronix proprietary halftone screens.

Macintosh file names	PC file names
<i>Setscreen On</i>	<i>SCREENON.PS</i>
<i>Setscreen Off</i>	<i>SCRENOFF.PS</i>
<i>LaserWriter Utility</i>	

Macintosh users

Note *If you are using QuickDraw GX and System Software 7.5, you can download printer utilities from the Tektronix Phaser 560 GX printer driver; refer to topics on the printer's CD-ROM or the Tektronix World Wide Web site for instructions.*

1. Follow the instructions starting on page 3-16 to install the utility files from either the printer's CD-ROM or the Printer Software for Macintosh diskette.
2. Select the appropriate printer in the Chooser.
3. Locate the *LaserWriter Utility* in the *PhaserTools* folder on your computer's hard disk, and double-click its icon to start the application.
4. Choose Download PostScript File from the Utilities menu.
5. Select one of the following files from the list, then click Open. (These files were installed in the *Phaser 560 Utilities* folder, inside the *PhaserTools* folder.)
 - Select *Setscreen On* to enable setscreen operations.
 - Select *Setscreen Off* to disable setscreen operations.
6. At the prompt `Save PostScript output as:` you are asked for a file name for saving printer output. Use either the default name given in the edit box or type a new name.
7. Click Save to send the file to the printer.
8. If no output is returned by the printer, the *LaserWriter Utility* displays a dialog box; click OK to continue.

PC and workstation users

1. Follow the instructions starting on page 3-1 to install the utility files from either the printer's CD-ROM or the software diskettes.
2. Locate the installed files in the *PHSR560* subdirectory, inside the *PHSRTOOL* directory on your computer's hard disk.
3. Use one of the following files:
 - Select *SCREENON.PS* to enable setscreen operations.
 - Select *SCRENOFF.PS* to disable setscreen operations.
4. Use one of the following methods to send a file to the printer:
 - **PC users:** Use the DOS COPY command, or the Copy command in Windows 3.1 File Manager, to send the file to the printer.
 - **Workstation users:** Send the file to the printer as you would any PostScript file.

Selecting page sizes in Windows applications

In some Windows applications, you can select printer page sizes in a Print Setup dialog box accessed from the File menu. If you use a Print Setup dialog box to select the Phaser 560 printer from your application, some page sizes may not be visible in the list.

If the Phaser 560 printer page size you want to use is not visible in the list, do the following:

Windows 3.1

1. From the Main window, open the Control Panel and double-click the Printers icon.
2. In the Printers dialog box, select Phaser 560 in the list of printers.
3. Click the Setup button.
4. In the Setup dialog box, select the page size you want and click OK.
5. Return to your application. If you open the Print Setup dialog box again from within your application, the page size selection may be blank. The page size you just selected in the driver is still selected, it is just not visible in the list.
6. Print as usual.

Note *If you open the Print Setup dialog box from within an application, and the page size selection is blank, the blank represents the page size last selected from the printer driver through the Control Panel. You can leave the page size selection blank and print as usual, or you can select a page size from the list.*

Windows 95

1. Click the Start icon in the taskbar on your screen; a menu appears.
2. Move the cursor over Settings; another menu appears.
3. In the menu, click Printers; the Printers window appears.
4. In the Printers window, select the Phaser 560 printer icon, then select Properties from the File menu.
5. Click the Paper tab.
6. Choose a page size, and click OK.
7. Return to your application.

Fonts printing incorrectly from Windows

If fonts are printing incorrectly from Windows, make sure that you installed the correct printer with the supported driver.

- If you have the standard printer configuration, you should have installed Tektronix Phaser 560.
- If you have the printer's Extended Features option with the additional fonts, you should have installed Tektronix Phaser 560 with Extended Features so that Windows recognizes and uses all the printer's 39 fonts.

Note *If you select Tektronix Phaser 560 with Extended Features and you have only the standard printer configuration with 17 fonts, any of the additional fonts selected within an application are printed in the Courier typeface.*

Getting printer configuration information

If you are not sure which printer configuration you have, print the Configuration Page from the printer's front panel; they list the amount of memory installed and whether your printer has the Standard or Extended configuration. Refer to "Printing Help Pages" on page 8-8 for instructions.

Refer to "PC/Windows software" on page 3-1 for instructions on installing the printer and drivers.

Sharing the printer on a network

Driver, utility files, and front panel interactions

If your printer is shared by other users on a network, you can affect prints made by other users when you use the downloadable utility files or the printer's front panel to change the printer's default color correction setting.

- When you print from a supported driver with any print feature selection *except* Use Printer Setting, the driver selection *overrides* the following selections *for prints made from the driver*:
 - A color correction utility file, if one has been downloaded.
 - The selection on the front panel **TekColor Corrections** menu.
- When you print from a supported driver with the Use Printer Setting option, your images are printed with one of the following selections:
 - A color correction utility file, if one has been downloaded to the printer.
 - The selection on the printer's front panel **TekColor Corrections** menu.
- When you print from a non-supported driver, your images can be printed with one of the following selections:
 - A color correction utility file, if one has been downloaded.
 - The selection on the front panel **TekColor Corrections** menu.
- If the colors on your prints are not what you expected, and your system administrator has disabled some of the printer's front panel menus, ask what settings are in effect and whether a color correction utility file has been downloaded to the printer. You can also print a Configuration Page to see the current color correction selection; see "Printing Help Pages" on page 8-8 for instructions.

If the LaserWriter Utility does not work (AppleTalk)

The *LaserWriter Utility* cannot be used if the printer is connected to a print server. See your system administrator to temporarily remove the printer from the print server to download any of the PostScript utility files.

Startup page prints even though it is disabled

The printer's power-up self-test can detect problems that do not necessarily make the printer completely inoperable. Examples of these *non-fatal* errors include faulty printer ports and some memory failures.

If the printer detects a non-fatal error at power-up, the startup page prints, even if you have disabled it. In this case, the page contains one or more of the error messages listed in the following table. Depending on your needs, you may not need to call for service immediately.

Error messages on the startup page

Message	Description
Parallel Port failed I/O Card failed SCSI Port failed	The named port is not working. The other ports can still be used.
DRAM SIMM <i>x</i> failed	One of the memory SIMMs is not working. In this message, <i>x</i> indicates the number of the SIMM that failed. Since the printer's base memory is still working, the printer can still be used, but throughput may suffer.
Extended SIMM failed	The Extended Features SIMM is not working. The printer can be used, but no access to CheckPrint, Quick Collate, and Copystation; no access to the 22 extra fonts. The base 17 fonts are still available, but requests for the optional fonts will be replaced with <i>Courier</i> .

Media hints and tips

Use high-grade media. For best reliability and image-quality, always use Tektronix media. Tektronix printers and Tektronix supplies are Made For Each Other[®]. Refer to “Phaser 560 Printer Supplies” on page 9-2 for ordering information. Do not use media designed for inkjet printers; they will damage the fuser.

Media handling

- Make sure that the media is dust-free. Dust and dirt can result in poor print quality.
- Handle media with both hands at the edges to avoid creases and fingerprints.
- Store media in the original, dust-free package in the same environmental conditions as the printer.

Double-sided printing

- Use laser bond paper (at least 100 g/m², 28 lb. bond for opacity and feed reliability) for duplexing; two-sided printing on specialty media can shorten component life.
- When printing side two of a duplex print in the Multi-Purpose Feeder, *always* select Paper 2nd Side (in the driver or the front panel) for the media type.
- For best results, do not use heavy toner coverage on Side 1.
- Duplex printing can reduce the life of the printer’s components and may require more frequent cleaning.

If your printer has a Lower Tray Assembly installed

- Place the most frequently-used paper in the PAPER tray and insert the tray in the printer’s *Upper* tray slot.
- Insert the TRANSPARENCY tray in the printer’s *Middle* tray slot.

Specialty media

- Always set the media thickness switch according to the media being used.
- When printing labels or envelopes, make sure that you use only the recommended types; refer to page 4-50 and page 4-48 for details.
- Printing on specialty media can reduce the life of the printer’s components and may require more frequent cleaning.

Clearing a media jam

If the printer has frequent media jams, make sure that you follow these guidelines:

- Always use high-quality laser paper and Tektronix-brand transparencies, glossy paper, and fabric transfer media.
- Make sure that you load specialty media *only* in the Multi-Purpose Feeder and that you set the Media Thickness switch to the correct setting for the media used.

If a media jam occurs, the front panel reports **Jam at <Location>**The <Locations>are the various sensors throughout the paper path, listed as **A** through **E**.

The following illustration shows the locations of the sensors that report a media jam (**A** through **E**).

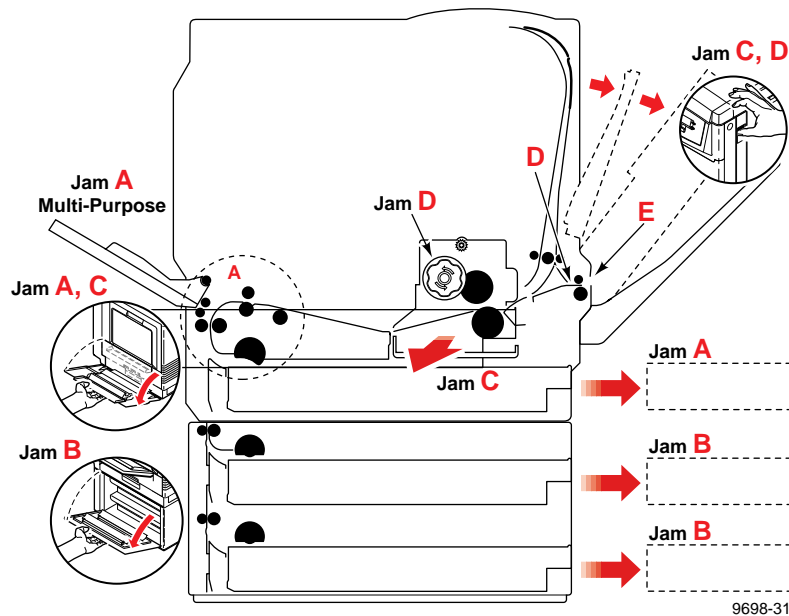

Jam at A

Solution 1

1. Open the left side door (if your printer has a Lower Tray Assembly installed, open the *Upper* left side door).

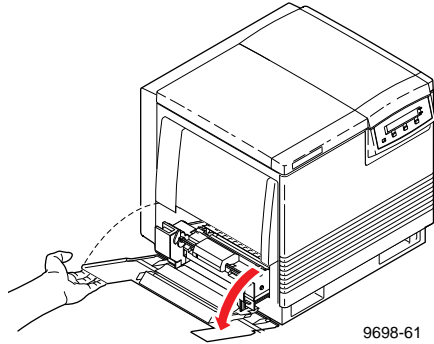

2. Remove the complete piece of jammed media.

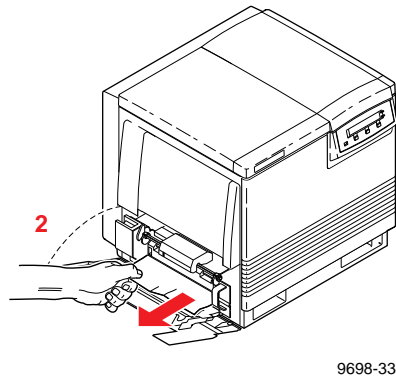

Solution 2

1. Remove the media tray (if your printer has a Lower Tray Assembly installed, remove the *Upper* media tray).

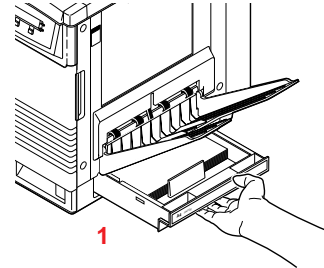

2. Remove the complete piece of jammed media from inside the printer.

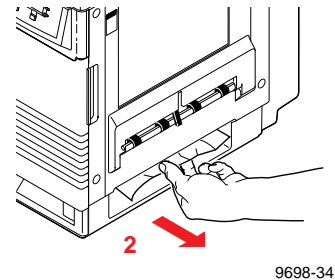

Jam at B

Solution 1

1. Open the *lower* left side door.

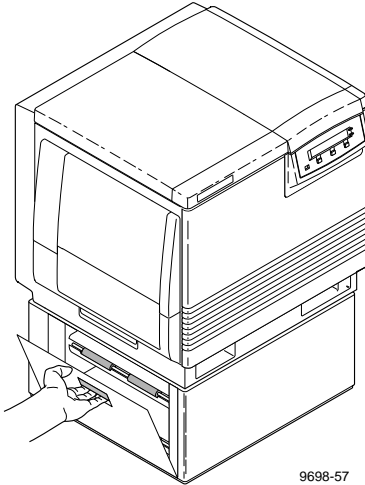

9698-57

2. Remove the complete piece of jammed media.

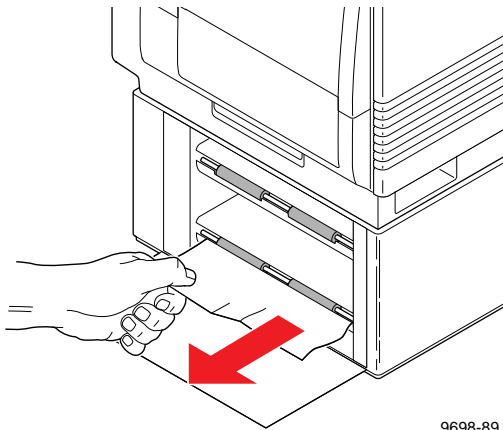

9698-89

Solution 2

1. Remove the selected media tray (*Middle or Lower* media tray).

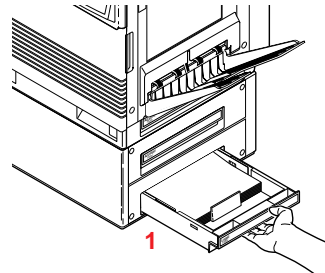

2. Remove the complete piece of jammed media from inside the printer.

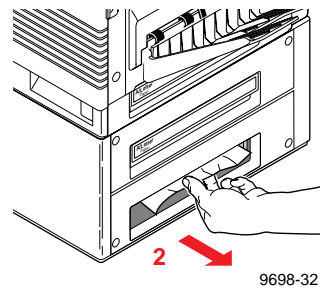

9698-32

Jam at C

Caution *The Fuser is hot; to avoid personal injury, wait 10 minutes for the Fuser to cool before touching it.*

1. Remove the Fuser:
 - a. Open the printer's front door.
 - b. Turn the small blue thumbscrew *counterclockwise* to unlock the Fuser.
 - c. Slide the Fuser out of the printer.

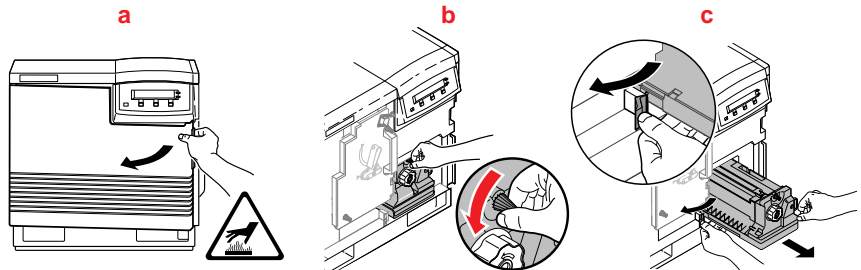

9698-35

2. Remove the Fuser Roll:
 - a. Press *out* on the two tabs to unlock the Fuser Roll.
 - b. Lift the Fuser Roll out of the Fuser and set it aside.

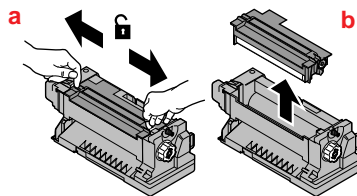

9698-42

Jam at C (cont'd.)

3. Turn the Fuser's large blue knob *clockwise* or *counterclockwise* to release the jammed media.
4. Remove the complete piece of jammed media from the Fuser.

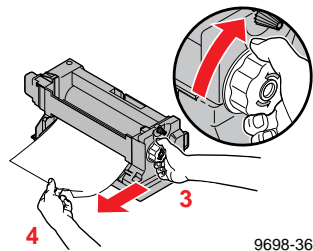

5. Re-insert the Fuser Roll into the Fuser (press firmly to snap it into place); re-install the Fuser.

Note *The Fuser must be removed and re-inserted to clear the front panel error message.*

Jam at D

Solution 1

Caution *The Fuser is hot. To avoid personal injury, open the front door and allow the Fuser to cool for 10 minutes before touching it.*

Warning *First check the exit opening for media that has jammed and folded like an accordion. It is especially difficult to see if the media is transparency film.*

1. Open the front door to access the Fuser.
2. Pull open the access door (above the plastic output tray); the media is visible.
3. On the Fuser, turn the large blue knob *counterclockwise*.
4. Remove the media from inside the access door.

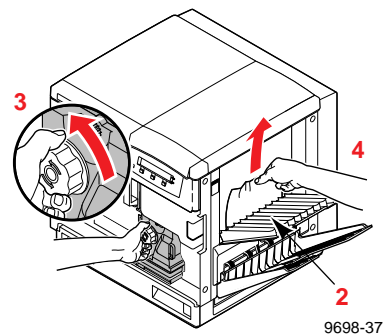

Caution *If the Fuser knob will not turn, do not force it or you may damage the Fuser. Instead, follow these steps:*

- *Unlock the Fuser by turning the small blue knob counterclockwise.*
- *Pull the Fuser out. The media will probably tear.*
- *Remove the Fuser Roll.*
- *Turn the Fuser's large blue knob to release the jammed media.*
- *Remove the jammed media from the Fuser and printer.*
- *Re-insert the Fuser Roll into the Fuser (press firmly to click it into place).*
- *Re-insert the Fuser.*

Jam at D (cont'd.)

Solution 2

Caution *The Fuser is hot. To avoid personal injury, open the front door and allow the Fuser to cool for 10 minutes before touching it.*

1. Open the front door *and* the right side door.
2. Turn the Fuser's large blue knob *counterclockwise* to release the jammed media.
3. Remove the jammed media from the right side of the printer.

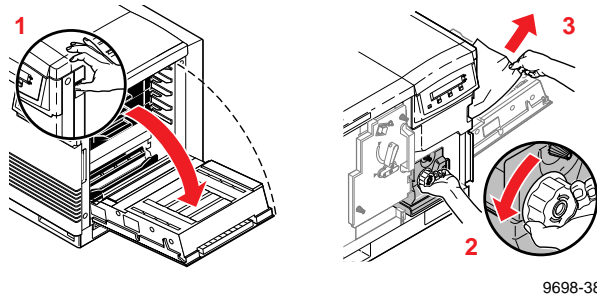

7 Troubleshooting

Jam at E

Solution 1

Remove the jammed media from the output tray.

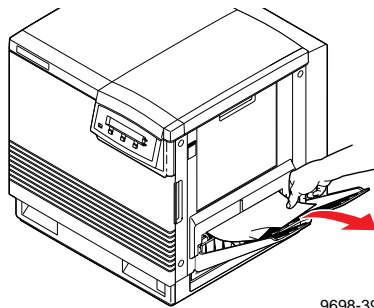

Solution 2

Pull open the access door (above the plastic output tray) and remove the media.

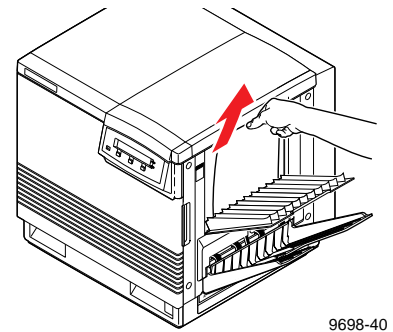

Jam at Multi-Purpose Feeder

1. Remove all media in the Multi-Purpose Feeder.
2. Remove the complete piece of jammed media from the Multi-Purpose Feeder.
3. Make sure that you set the Media Thickness switch for the media that you are using.
4. Re-insert the media in the Multi-Purpose Feeder.
5. Open and close the printer's front door to clear the error message in the front panel.

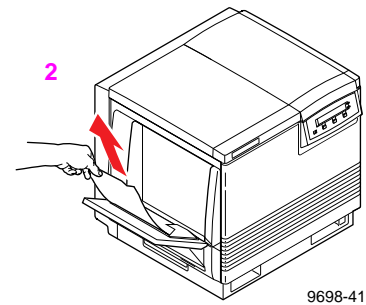

Using the Front Panel

Front panel

The front panel provides a display of two lines of 24 characters each for messages, button labels, and user-adjustable parameter settings.

Front panel indicators

The front panel includes two indicator lights:

1. **Power** (green LED)
2. **Error** (red/amber LED)

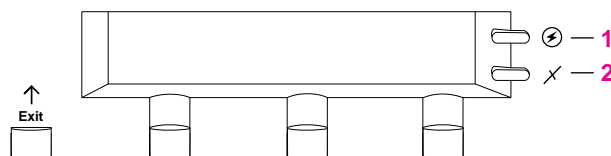



9008-34

Indicator	On	Blinking	Off
1. Power	The printer is on and ready for operation.	The printer is processing or printing an image. The printer is in interactive mode: you have pressed the Menu button.	The printer is not ready, or there is an error.
2. Error	If the indicator is on after the power-up sequence, some user interaction is required (for example, toner is low). Check the front panel message.	The printer requires immediate user interaction (for example, clear a media jam or close an open door). Refer to "Troubleshooting and print quality quick reference" on page 7-7.	Normal operation: there are no print engine or controller board errors.

Front panel buttons

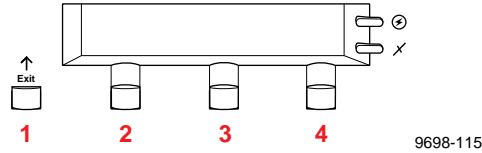
The front panel buttons function according to which of these states (modes) the printer is in:



Mode	Front Panel Buttons			
	1	2	3	4
Ready / Printing Idle mode or Normal operating mode		Info Provides printer information when pressed. Refer to page 8-5 for detailed information.		Menu Accesses the front panel menu.
Printing Printing mode			Cancel Cancels a job that is printing.	Menu Accesses the front panel menu.
Processing Data is being processed			Cancel Cancels a job that is processing.	
Interactive Press Menu	 Backs up a level of the menu without making a selection.	<--- Scrolls backward through the available selections.	---> Scrolls forward through the available selection.	Menu Accesses front panel submenus.
	 Exits the menu and returns the printer to Ready .		Confirm Implements a selection.	Print Executes a print command.
				OK Accepts the selected value.
				View Allows the user to view information.
				Reset Resets the count for a user-replaceable component.

Mode	Front Panel Buttons			
	1	2	3	4
Check Print		Reprint	Cancel	Continue
Driver selection		Reprints the first page of the print job. Refer to page 5-11 for detailed information.	Cancels the current print job.	Completes the current print job.
Diagnostics		Info		
Printer detects an error and stops		Provides printer information when pressed. Refer to page 8-5 for detailed information.		
		More		
		Displays more information about the nature of the error.		
Standby (Energy Star) Conserving energy			Wake Up	
		Pressing any key activates the warm-up process, eventually bringing the printer to the Ready state.		

Two-line display

The two lines of the display have the following functions:

Line a

- Displays status messages such as **Ready** and **Printing**
- Displays operation errors and warnings such as **<color>: low**
- Displays the names of menus and parameters you can set.

Line b

- Displays button labels such as **<--** for *previous* and **-->** for *next* (for moving through selections in a given menu), **Menu** for access to a menu of selections, and **Print** and **OK** to make selections.

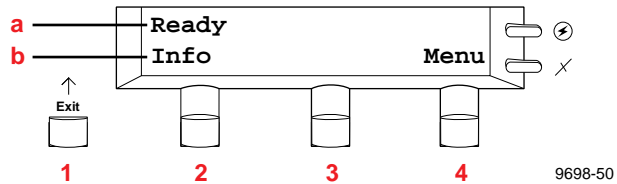

For a roadmap to the front panel menu selections, turn to “Front panel menu map” on page 8-7.

Printer information

The second button on the front panel (2) allows you to access the following information from the printer's current settings; this information appears on the upper line of the front panel display (a); the second line of the display (b) provides the **More** label for the second button.

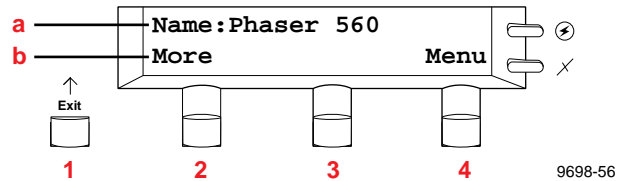

The type of information varies, depending on what the current mode is.

Info Button (2) Capability

Idle Mode	Processing / Printing Mode	Fault Mode
<p>Printer name The name assigned to the printer by the system administrator.</p>	<p>User name The name of the user sending the current print job.</p> <p>Print server The name of the print server spooling the current print job.</p>	<p>Fault Code</p> <p>Action Suggested action to correct fault.</p>
<p>IP address Internet address assigned to the printer by the network administrator.</p>	<p>Job name The name of the current print job being processed or printed.</p>	

Protected mode for the front panel menu

System administrators may choose to limit user access to front panel menus by downloading a utility file to the printer. The “lock” utility file prevents most menu items from being displayed on the front panel. The capability of limiting menu access is often useful when a system administrator needs to retain control of the printer’s settings. In the protected mode, users still have access to print the Consumables Page, Configuration Page, Startup Page, and Demonstration Page.

In the protected mode, you can still access the full menu structure through a combination of front panel button pushes. An “unlock” utility file can also be downloaded to the printer to unlock the front panel menu for user viewing.

To learn more about locking and unlocking the front panel menus, refer to the topics on the printer’s CD-ROM or the Tektronix World Wide Web site or call the Tektronix Customer Support Hotline at 1-800-835-6100 (from 6:00 am to 5:00 pm PST).

Use the following key sequence to access the entire menu when the front panel is “locked:”

- Press and hold down the **Menu** button and press the  button.

The **Help Pages** menu in the front panel menu includes a front panel menu map. Refer to “Front panel menu map” on page 8-7. For instructions on printing the menu map, refer to “Printing Help Pages” on page 8-8.

Front panel menu map

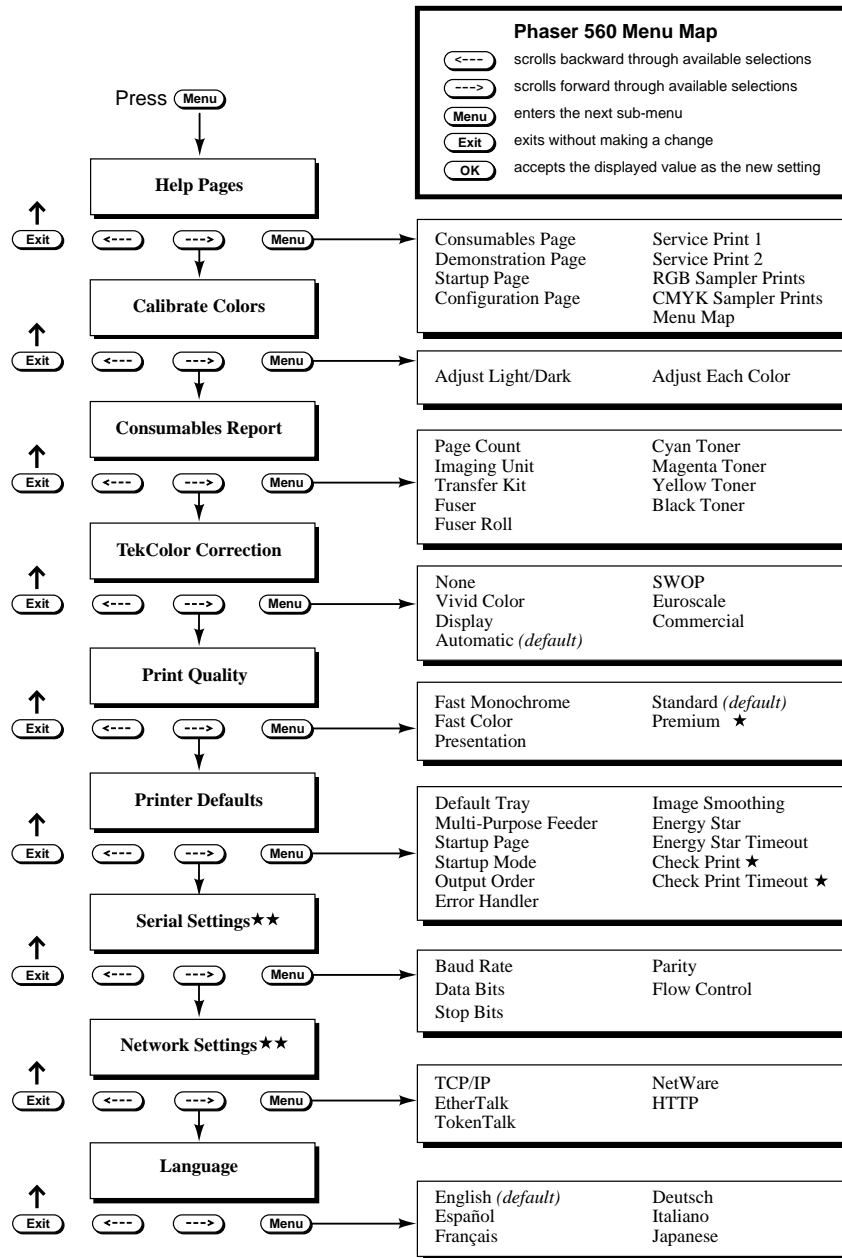

★Optional configuration.

★★Appears when optional PhaserShare™ card is installed.

Printing Help Pages

The printer has several **Help Pages** that you can print to learn more about the printer.

- Consumables Page * Provides a test pattern to diagnose and correct print-quality problems. Includes a gauge for each consumable showing % Remaining.
- Demonstration Page: Provides a colorful way of learning more about the printer while demonstrating its printing quality. Prints in the currently selected print quality and color correction modes.
- Startup Page: Lists the number of pages printed, installed interface ports, software version numbers, installed RAM memory, the number of fonts, and other useful information. Automatically prints at power-up unless disabled in the front panel (refer to “Enabling and disabling the Startup Page” on page 8-10).
- Configuration Page * Lists general information on printer settings and how the printer is configured (Standard or Extended Features). Includes the copy count for each of the consumables. Useful for network installation and troubleshooting.
- Service Print 1: Provides diagnostic pages for users and service technicians to correct print quality problems.
- Service Print 2: Provides diagnostic pages for service technicians.
- RGB Sampler Prints: Prints a sample of colors in the RGB (red, green, and blue) color model (12 pages).
- CMYK Sampler Prints: Prints a sample of colors in the CMYK (cyan, magenta, yellow, and black) color model. (18 pages).
- Menu Map: Provides a graphical view of the front panel menus.

* Before calling the Customer Support Hotline, always print this page; it contains useful diagnostic information.

To print any of the front panel's **Help Pages** follow these steps:

1. While the **Ready** message is displayed, press the **Menu** button. The printer displays the first item in the menu:

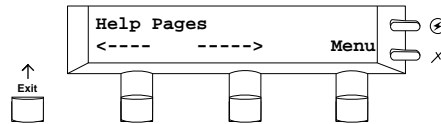

2. Press the **Menu** button to enter the **Help Pages** menu.
3. Press the left (**<---**) or right (**---**) button until the printer displays the name of the page you want to print. These are the selections:

Consumables Page
Demonstration Page
Startup Page
Configuration Page
Service Print 1
Service Print 2
RGB Sampler Prints
CMYK Sampler Prints
Menu Map

4. Press the **Print** button to print the desired page.

Enabling and disabling the Startup Page

You can enable and disable printing of the Startup Page in three ways:

- On a PC, send a PostScript language utility file to the printer. For more information, refer to the topics on the printer's CD-ROM or the Tektronix World Wide Web site.
- On a Macintosh, use the *LaserWriter utility* to download a utility file.
- Through the printer's front panel, according to the following instructions:
 1. While the **Ready** message is displayed, press the **Menu** button. The printer displays the first item in the menu:

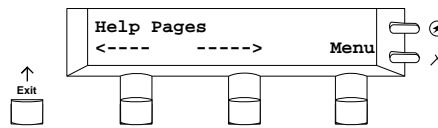

2. Using the left arrow (<---) or right arrow (--->) buttons, scroll through the selections until the following message appears:

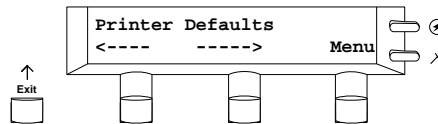

3. Press the **Menu** button to access the printer defaults settings.

4. Using the left arrow (<-->) or right arrow (--->) buttons, scroll through the selections until the following message appears:

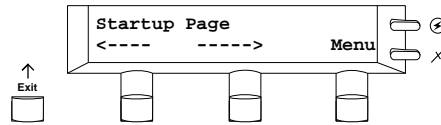

5. Press the **Menu** button to access the Startup Page settings.
6. Press the right arrow (--->) button once for the following message:

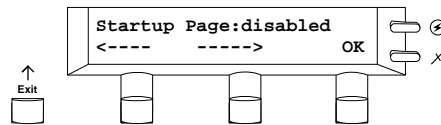

7. Press the **OK** button to disable printing of the Startup Page.

To return to the top level of the menu, press the **Exit** button until the printer displays the **Ready** message.

Supplies, Accessories, and Expanding Your Printing System

Tektronix Printer and Tektronix supplies: Made For Each Other[®]

Tektronix supplies are developed and tested as a total *system*: printer, user-replaceable components, and media. These system components work together to produce consistent, high-quality color images.

Always order Tektronix supplies for your Phaser 560 printer to guarantee the best print quality, media feed reliability, and trouble-free printer performance.

Customizing your printer

Tektronix offers upgrade and accessory kits to expand your printer's capabilities. Refer to the information provided here or refer to the supplies information sheet that was shipped with the printer. To order, contact your local dealer or Tektronix office. In the United States, call Tektronix at 1-800-835-6100.

Supplies and accessories

Phaser 560 Printer Supplies

	Order number	Description	
Supplies			
High Capacity Toner cartridges	016-1536-00	Black	
	016-1537-00	Cyan	
	016-1538-00	Magenta	
	016-1539-00	Yellow	
Fuser	016-1534-00	110 volt	
	016-1535-00	220 volt	
Fuser Roll	016-1556-00		
Imaging Kit	016-1523-00		
Transfer Kit	016-1533-00		
Main Charge Grid	118-9070-02		
Media			
Laser paper	016-1368-00	A/Letter (U.S.)	500 sheets
	016-1369-00	A4 (Metric Letter)	500 sheets
Glossy Coated paper 100 lb./150 g/m ²	016-1557-00	A/Letter (U.S.)	100 sheets
	016-1558-00	A4 (Metric Letter)	100 sheets
Fabric transfer	016-1637-00	A/Letter (U.S.)	100 sheets
Transparencies	016-1531-00	A/Letter (U.S.)	50 sheets
	016-1532-00	A4 (Metric Letter)	50 sheets

Phaser 560 Accessories

Accessories	Order Number	Description
	436-0282-01	A/Letter paper tray
	436-0283-01	A4 paper tray
	436-0284-01	A/Letter transparency tray
	436-0285-01	A4 transparency tray
	436-0314-00	Legal paper tray
	118-9536-00	Output tray
	4676FTA	Lower Tray Assembly (includes one A/Letter paper tray and one A/Letter transparency tray; order Option 01 for metric trays)
	352-1066-00	Documentation holder
	4540	Phaser Copystation printer accessory
	065-0566-00	Repackaging kit
	650-3572-00	Rebanding kit
Manuals	070-9698-00	<i>Phaser 560 Color Laser Printer User Manual</i> ; order Option L1, L2, L3, or L4 for French, Italian, German, Spanish manuals, respectively
	063-2564-00	<i>Phaser 560 Color Laser Printer Quick Reference Guide</i> ; order Option L1, L2, L3, or L4 for French, Italian, German, Spanish manuals, respectively
	063-2844-00	<i>Phaser 560 Color Density Samples</i>
	070-9538-01	<i>PhaserShare Network Cards and Software System Administrator User Manual</i>
	070-9539-01	<i>PhaserShare Status Software User Manual</i>
Printer software	063-1613-00	Phaser 560 Printer Software diskettes
	063-2563-00	Phaser 560 printer CD-ROM
Cleaning supplies	006-7824-01	Pre-soaked alcohol cleaning wipes (packet of 10)

Interface cables and adapters

The following cables and adapters are available through Tektronix or your dealer. Contact your dealer for other cables and adapters.

Printer interface cables and adapters

Order number	Description	Connectors and cable length
012-1468-00	Parallel cable	36-pin high-density plug to 25-pin DSUB plug; 3 meters (9.84 feet)
	Connects the printer's parallel port to a PC or workstation parallel port.	
013-0299-00	Parallel/Centronics adapter	parallel adapter: converts 36-pin low-density 1284-B plug to 36-pin high-density 1284-C plug
	Adapts your system's existing low-density, Centronics parallel cable connector to the printer's high-density parallel connector.	
012-1465-00	SCSI-2 HD to SCSI-1 LD cable	50-pin high-density plug to 50-pin low-density plug; 2.0 meters (6.56 feet)
	Connects the printer's SCSI port to a hard disk drive or the Phaser Copystation SCSI port.	
012-1299-00	SCSI-1 LD to Macintosh SCSI cable	50-pin low-density plug to Macintosh SCSI 25-pin plug
	Combine with 013-0297-00 to connect the printer's SCSI port to a hard disk drive with Macintosh SCSI 25-pin plug.	
013-0297-00	SCSI-1 LD to SCSI-2 HD adapter	SCSI adapter: converts 50-pin low-density plug to 50-pin high-density plug
	Use with either 012-1465-00 or 012-1299-00 to convert a low-density SCSI connection to a high-density SCSI connection.	
012-1379-00	Serial (RS-232) Null modem cable	9-socket receptacle to 9-pin socket; 1.8 meters (6 feet)
	Connects the printer's serial port to a PC or workstation serial port.	
012-1380-00	Serial (RS-232) Null modem cable	9-socket receptacle to 25-pin socket; 1.8 meters (6 feet)
	Connects the printer's serial port to a PC or workstation serial port.	

Expanding your printing system

Upgrade kits

Order number	Description
ZMA16	16-Mbyte SIMM for adding memory (Option 16); see “Advantages of adding memory” on page 9-7.
ZMA32	32-Mbyte SIMM for adding memory (Option 32); see “Advantages of adding memory” on page 9-7.
Z560FX	Extended Features SIMM for 22 additional fonts, Premium print-quality mode, Quick Collate and Check Print features, 1200 dpi support, and Copystation support. Includes an additional 32 Mbytes of RAM, for a total of 40 Mbytes.
Z560FJ	Extended Features SIMM for Kanji fonts, Premium print-quality mode, Quick Collate and Check Print features, 1200 dpi support, and Copystation support.
Z350FP1	Ethernet networking card upgrade kit; includes EtherTalk, Novell NetWare, and TCP/IP protocols (Option P1).
Z350FP3	LocalTalk networking card upgrade kit; includes LocalTalk protocol and RS-232 (serial) interface (Option P3).
Z350FP4	Token Ring Networking Card upgrade kit (Option P4). Includes TokenTalk, Novell NetWare, and TCP/IP.
Z350DSK	Phaser SCSI hard disk
Z560SS	Supplies Startup Kit.
4540	Phaser Copystation accessory adds color copying capability to your Tektronix Phaser printer.

Extended Features upgrade

In its standard configuration, the Phaser 560 printer offers 8 Mbytes of RAM memory (expandable to 72 Mbytes), 17 fonts, and PhaserLink™ software, Tektronix' online control of printer features and access to printer information through a standard web browser. The Extended Features upgrade is especially suited for workgroups, enhancing the printer's performance in the following ways:

- **Z560FX** Adds 22 Roman fonts for a total of 39 fonts; adds 32 Mbytes of RAM, for a total of 40 Mbytes.
- **Z560FJ** Adds 2 Kanji fonts for a total of 17 Roman, 2 Kanji fonts.
- Provides support for the Premium print-quality mode.
- Provides 1200 x 1200 dpi resolution.
- Provides the Quick Collate feature, allowing you to collate jobs in the printer.
- Provides the Check Print feature that lets you to preview the first page of a multi-page job before printing the entire file.
- Adds support for the Phaser Copystation.

Note *If you are not sure which printer configuration you have, print the startup page from the Help Pages menu in the front panel; look for the entry for Extended Features (Yes or No).*

To order the Extended Features upgrade for a Phaser 560 printer, use Tektronix order number Z560FX (Roman fonts) or Z560FJ (Kanji fonts).

Memory upgrade

The Phaser 560 printer has 8 Mbytes of standard memory. You can upgrade the printer's memory with one or two 16- and 32-Mbyte SIMMs (for a total of 24, 40, 56, or 72 Mbytes).

Note *If you are not sure which printer configuration or how much memory is installed in your printer, print the startup page from the Help Pages menu in the front panel; look for the entry for RAM Memory.*

Advantages of adding memory

In general, more memory improves throughput, reduces the level of compression, provides more storage for downloadable fonts, and allows printing of the most complex images. Additional memory can also reduce offload time by increasing the size of input buffers for the I/O ports.

Specifically, more memory provides support for the Phaser Copystation.

Memory configurations for the Phaser 560 printer

Memory	Total memory	Performance / Benefit
Standard	8 Mbytes	Base configuration supports Fast Monochrome , Fast Color , Presentation , and Standard print modes.
Add one 16-Mbyte SIMM	24 Mbytes	Increases frame buffer size, I/O buffers, and virtual memory. Improves throughput. Full frame buffer for Standard mode. Minimum requirement for Premium mode printing (with Extended Features); Letter-size copies on the Phaser Copystation.
Add one 32-Mbyte SIMM (Included with the FX option)	40 Mbytes	Increases frame buffer size, I/O buffers and virtual memory — two full frame buffers for Standard mode, one full frame buffer for Premium mode (Premium mode requires the Extended Features configuration). Minimum requirement for Legal-size copies on the Phaser Copystation.
Add one 16-Mbyte SIMM and one 32-Mbyte SIMM	56 Mbytes	Increases the size of caches, buffers, and virtual memory to reduce the amount of time required to transfer large images and to process multiple jobs.
Add two 32-Mbyte SIMMs	72 Mbytes (max.)	1200 x 1200 dpi without compression guarantees the fastest throughput and best image quality.

PhaserShare network cards

Tektronix PhaserShare™ network cards offer high-performance network connectivity for your color printer. PhaserShare network cards can be easily installed in your printer.

Order number	Description
Z350FP1	Adds Ethernet interface; includes support for Novell NetWare, EtherTalk, TCP/IP, Telnet and FTP. (Same as Option P1.)
Z350FP3	Adds LocalTalk/Serial interface. (Same as Option P3.)
Z350FP4	Adds Token Ring interface; includes support for Novell NetWare, TokenTalk, TCP/IP, Telnet and FTP. (Same as Option P4.)

Benefits of networking the printer

Adding a PhaserShare network card to your printer makes it an efficient, sharable printing resource in network environments. Network connections, such as Ethernet, offer significant speed improvements compared to the standard parallel communication connection. Several varieties of PhaserShare cards allow the printer to be seamlessly integrated into popular network configurations. All ports and protocols are simultaneously active, allowing the printer to be used in mixed environments.

Phaser Copystation accessory

The Phaser Copystation accessory adds easy-to-use, walk-up color copying capability to the Phaser 560 Color Laser Printer.

The Copystation's front-panel controls let you specify the number of copies and select among color, gray scale and black-and-white copying modes. You can choose to make copies reduced to 25% or enlarged to 200% of the original's size, and you can adjust copies for color balance and lightness.

To use a Phaser Copystation with the Phaser 560 printer, your printer requires the following memory upgrades:

- 16-Mbyte SIMM (total 24 Mbytes) *Letter-size copies*
- 32-Mbyte SIMM (total 40 Mbytes) *Legal-size copies*

Note To order a Phaser Copystation, use Tektronix order number 4540.

For instructions on connecting a Phaser Copystation to your printer or printer network, and for operating instructions, refer to the *Phaser Copystation User Manual*.

Lower Tray Assembly

The Lower Tray Assembly adds two more media trays to your printer, each tray with a 250-sheet capacity. This transforms the printer into a high-volume printing solution for networked environments. Multiple-tray printing capability is especially useful if you commonly print on both paper and transparency or Letter- and Legal-sized media. For ordering information, refer to "Supplies and accessories" on page 9-2.

PhaserPrint for UNIX

For printing in UNIX environments, Tektronix offers PhaserPrint™ for UNIX software which provides fast raster file and screen copy printing to Tektronix color printers. PhaserPrint for UNIX software also provides a graphical user interface for push-button control of Tektronix printer features. PhaserPrint for UNIX software works with the workstation's native spooling system to print PostScript files and convert raster files to PostScript from the Sun Raster Format (SRF), xwd, SGI RGB, and other formats.

The printer's CD-ROM contains a demonstration copy of the PhaserPrint for UNIX software and an on-line instruction guide in the *phaserpr.unx* directory. Refer to "Printing from a workstation" on page 4-18 for more information.

Note *To order PhaserPrint for UNIX software, use Tektronix order number 4690F20.*

SCSI hard disk

You can attach a Tektronix-approved external SCSI hard disk (order number Z350DSK) to the printer's SCSI port. You can connect one or more external SCSI hard disks to the printer for additional font storage. Contact Technical Support for recommended SCSI disk drives.

Regulatory Information and Specifications

Canadian EMC (Electromagnetic Compatibility) regulatory standards

- This digital apparatus does not exceed the Class B limits for radio noise emissions from digital apparatus set out in the Radio Interference Regulations of the Canadian Department of Communications.
- Le présent appareil numérique n'émet pas de bruits radioélectriques dépassant les limites applicables aux appareils numériques de la classe B prescrites dans le Règlement sur le brouillage radioélectrique édicté par le ministère des Communications du Canada.

Declaration of conformity (for 220-230 VAC equipment)

Tektronix, Inc.
 Color Printing and Imaging Division
 P.O. Box 1000
 Wilsonville, Oregon 97070-1000 U.S.A.

declares, under our sole responsibility, that the product

Phaser 560 (Z560A)

to which this declaration relates, is in conformity with the following standard(s) or other normative document(s):

For the EC EN60950:1992	Safety of Information Technology Equipment including Electrical Business Equipment
For the EC EN55022:1992	Limits and methods of measurement of radio Interference characteristics of Information Technology Equipment
For the EC EN61000-3-2:1995	Part 3: Limits - Section 2: Limitations of harmonic current emissions (equipment input current $\leq 16A$ per phase).
For the EC EN61000-3-3:1994	Part 3: Limits - Section 3: Limitation of voltage fluctuations and flicker in low-voltage supply systems for equipment with rated current $\leq 16A$.
For the EC EN50082-1:1992	The Generic Immunity Standard Residential, Commercial, and Light Industry.

Environmental Phenomena	Test Specification	Basic Standard
Radio-Frequency Electromagnetic Field	27 - 500 MHz	IEC801-3:1984
Electrostatic Discharge	8kV (charge Voltage)	IEC801-2:1984
Fast Transients common mode on Signal lines	0.5kV (peak) 5/50 Tr/Th ns 5kHz Rep. Frequency	IEC801-4:1988 Capacitive Clamp
AC mains ports	1kV	

following the provision of the
 Low Voltage Directive 73/23/EEC, the Electromagnetic Compatibility Directive
 89/336/EEC, Machinery Directive 89/392/EEC.

FCC Class B device (for 100-120 VAC equipment)

The equipment described in this manual generates and uses radio frequency energy. If it is not installed and used properly in strict accordance with Tektronix' instructions, it may cause interference with radio and television reception.

This equipment has been tested and verified to comply with the limits for a Class B digital device, pursuant to Part 15 of the FCC Rules. These limits are designed to provide reasonable protection against harmful interferences in a residential installation. This equipment generates, uses and can radiate radio frequency energy and, if not installed and used in accordance with the instructions, may cause harmful interference to radio communications. However, there is no guarantee that interference will not occur in a particular installation. If this equipment does cause harmful interference to radio or television reception, which can be determined by turning the equipment off and on, the user is encouraged to try to correct the interference by one of more of the following measures:

- Reorient or relocate the receiving antenna.
- Increase the separation between the equipment and receiver.
- Connect the equipment into an outlet on a circuit different from that to which the receiver is connected.
- Consult the dealer or an experienced radio/TV technician for help.

Warning *Changes or modifications not expressly approved by Tektronix can affect emission compliance and could void the user's authority to operate this product. To ensure emission compliance, use shielded interface cables.*

Material Safety Data Sheets

Proper management of environmental resources protects the well-being of our employees, customers, shareholders, and the communities we are a part of worldwide.

Tektronix establishes and maintains sound environmental management practices to accomplish this goal and to assure compliance with the laws, regulations, and orders of the responsible governmental authorities wherever Tektronix and its subsidiaries operate.

Tektronix, Incorporated is complying with government regulations by providing Material Safety Data Sheets for this product.

*Color Printing and Imaging Division
Tektronix, Incorporated*

MSDS for Toner

Section 1 – Product Identification

Trade Names/Tektronix Part Number:

<i>Black Toner Cartridge</i>	016-1536-00
<i>Cyan Toner Cartridge</i>	016-1537-00
<i>Magenta Toner Cartridge</i>	016-1538-00
<i>Yellow Toner Cartridge</i>	016-1539-00

Product Use: Tektronix Phaser® 560 printers

Section 2 – Information On Ingredients

Ingredients

Toners are a proprietary blend of pigments and resins, encased in a sturdy housing.

Section 3 – Hazards Identification

ROUTES OF EXPOSURE: Toner powders are encased in a cartridge housing and are not accessible, unless cartridge is forcibly broken.

POTENTIAL HEALTH EFFECTS: Health effects from this product are expected to be very low, when product is used as intended.

Immediate Effects:

Inhalation: Minimum irritation to respiratory tract, as for any non-toxic dust.

Skin: Expected to be low hazard to skin, when used as intended.

Eye: May cause mild irritation.

Ingestion: Not an expected route of exposure.

Chronic Effects: None known or expected.

Section 4 – First Aid Measures

Inhalation: Unlikely route of exposure. In the event of exposure, remove person to fresh air. Seek medical attention if symptoms occur.

Eyes: Contact unlikely. If any particles get into eye, flush thoroughly with water. Seek medical attention if symptoms occur.

Skin: Wash thoroughly with water. Seek medical attention if symptoms of irritation occur.

Ingestion.: Seek medical attention immediately.

Section 5 – Fire Fighting Measures

Flammable Properties:

Flash Point: Not applicable.

Fire & Explosion Hazards: These toners will burn. No unusual hazards are expected.

Extinguishing media: CO₂, dry chemical, foam, or water.

Section 6 – Accidental Release Measures

Spill Or Leak: Toners are encased in a sturdy housing. However, in case of breakage, toner powders may be cleaned up with a broom or vacuum. Clean up residue if necessary with soap and water.

Section 7 – Handling And Storage

Handling: None.

Storage: Avoid high temperatures.

Section 8 – Exposure Control – Personal Protection

No special protection indicated when used as intended.

TLV/PEL: Black toner contains carbon black, which has an OSHA Permissible Exposure Limit (PEL) of 3.5 mg/m³ (milligrams per cubic meter of air), as an eight-hour time-weighted average. The ACGIH Threshold Limit Value (TLV) is also 3.5 mg/m³.

Section 9 – Physical And Chemical Properties

Appearance: Black, blue, red, or yellow powders.

Odor: None.

Solubility: Not water soluble.

Section 10 – Stability And Reactivity

Stability: Stable.

Incompatibility With Other Materials: Strong acid or alkaline materials.

Hazardous Polymerization: Will not occur.

Section 11 – Toxicological Information

Toxicity: Expected to be not toxic, as determined by standard laboratory tests for acute, oral toxicity performed on very similar toners.

Carcinogenicity: Not listed by NTP or OSHA. Black toner contains carbon black, which has been classified by the International Agency for Research on Cancer (IARC) as a class 2B carcinogen, possibly carcinogenic to humans. However, toners very similar to these have been tested in bacterial assays for mutagenicity (Ames Test) and were found to be not mutagenic.

Section 12 – Ecological Information

No known impact.

Section 13 – Disposal Considerations

These products are not a hazardous waste as specified in 40CFR 261. Dispose in accordance with all federal, state, and local regulations.

Section 14 – Transport Information

DOT: Not regulated.

Section 15 – Regulatory Information

TSCA: All components of these inks are listed in the Toxic Substances Control Act inventory as verified by our suppliers.

RCRA: TCLP below hazardous waste levels set by EPA.

Section 16 – Other Information

Original preparation date: July 21, 1997. JMP

Tektronix, Incorporated

P.O. Box 500

Chemical Documentation

Mail Stop 46-825

Beaverton, Oregon 97077

Printer information: 1-800-835-6100

MSDS information: (503) 627-7255

Specifications

Temperature

Operating: 10° C to 32.5° C (50° F to 90.5° F)

Best Print Quality: 15° C to 25° C (59° F to 77° F)

Non-operating: 0° C to 40° C (32° F to 104° F)

Storage: (without paper, transparencies, or consumables): -20° C to +60° C (-4° F to +140° F)

Humidity

Operating: 10% to 80% Relative Humidity, non-condensing

Best Print Quality: 30% to 60% Relative Humidity, non-condensing

Non-operating: 10% to 90% Relative Humidity, non-condensing

Altitude

Operating: 0 to 2,500 m (8,000 ft.).

Non-operating: 0 to 4000 m (13,125 ft.)

Primary voltage ranges

90 - 132 VAC, 110 VAC nominal

198 - 264 VAC, 220 VAC nominal

Frequency range

50 to 60 Hz

Primary fusing

125 VAC, 10 Amps and 6.3 Amps

250 VAC, 6.3 Amps

(Not user-accessible)

Power Consumption

Meets Energy Star power conservation requirements.

State	Average power
Continuous printing	208 W
Idle	130 W
Energy Star	45 W or under

Dimensions of standard unit (without Lower Tray Assembly)

Height: 463 mm (18.2 in.)

Depth: 492 mm (19.4 in.)

Width: 507 mm (20* in.)

*782 mm (30.8 in.) with the output tray

Dimensions with Lower Tray Assembly

Height: 678 mm (26.7 in.)

Depth: 492 mm (19.4 in.)

Width: 507 mm (20* in.)

*782 mm (30.8 in.) with the output tray

Weight of standard unit with all consumables (without Lower Tray Assembly)

47.5 kg (104.6 lbs.)

Weight of Lower Tray Assembly

14.3 kg (31.6 lbs.)

Printing speed

The speeds and rates listed in the following table represent the time it takes the printer to produce a print (**1st print**) and the rate at which the printer produces multiple prints (**Continuous throughput rate**). In both cases these are physical mechanism times, independent of image processing time. Actual time to first print depends on image complexity and size, resolution, and memory configuration.

Print mode	Color		Monochrome	
	1st print	Continuous throughput rate (ppm)*	1st print	Continuous throughput rate (ppm)*
Fast Monochrome	26 sec.**	14 **	26	14
Fast Color	40 sec.	4.7	55 sec.	4.7
Standard / Presentation	43 sec.	3.5	26 sec.	14
Premium	1 min. 20 sec.	1.8	50 sec.	7
Transparency	1 min. 20 sec.	1.5	60 sec.	7

* Pages per minute.

** Output from Fast Monochrome will always be black-and-white.

Safety and emissions standards

FCC Part 15, Subpart J “Class B” verified

Vfg 243 Class B

CISPR 22 Class B, verified

UL 1950, listed.

CSA 220, certified.

EN60950/IEC 950, TUV licensed

EN55022

Index

A

- A/Letter media trays 4-34
 - ordering 9-3
- A/Letter media, dimensions 4-30
- A4 media trays 4-34
 - ordering 9-3
- A4 media, dimensions 4-30
- accessories, ordering 9-3
- adapters, ordering 9-4
- additional memory 9-7
- adjusting color density 5-2
- adjusting printed colors 5-17
- Adobe Photoshop plug-in 3-17
- Adobe PostScript driver 4-10
- advantages of networking
 - PhaserShare cards 9-8
- Apple LaserWriter 8 driver
 - setting up 3-20
 - using 4-16
- applications, color adjusting 5-24
- automated fax systems (HAL/EuroHAL)
 - printing hints and tips 7-3
- Automatic color correction
 - description 5-20
 - when to select 5-17
- automatic language selection 4-29
- automatic tray switching 5-14

B

- blue color adjust 5-21

C

- cables, ordering 9-4
- Calibrate Colors** menu 5-2
 - selections 5-7
 - troubleshooting 7-9
- card stock
 - loading Multi-Purpose Feeder 4-46

CD-ROM

- installing printer software 3-1
- ordering printer software 9-3
- unpacking the printer 2-2

changing languages

- front panel selection 2-22
- PostScript, HP-GL, PCL5 4-29

Check Print

- driver selection, Macintosh 4-14
- driver selection, Windows 4-3
- front panel menu map 8-7
- resetting the timeout 5-11

Chooser

- printer doesn't appear 7-16
- selecting a driver 7-16
- setting up the LaserWriter 8 driver 3-20
- setting up the Phaser 560 driver 3-19
- setting up the Phaser 560 GX driver 3-21

CIE colors 5-17

cleaning 6-12

CMYK color sampler chart 5-25

CMYK utility file 5-26

coated (glossy) paper

- loading Multi-Purpose Feeder 4-46
- ordering 9-2

collating multiple copies 5-8

color

- adjusting or correcting 5-17
- how to use 5-16
- problems with 7-29

color charts (RGB, CMYK, HSB) 5-26

color correction

- Automatic 5-20
- CMYK color sampler chart 5-25
- Commercial Press 5-22
- descriptions 4-24
- Euroscale Press 5-22
- from an application 5-24
- front panel selection 4-21

- color correction (cont'd.)
 - None 5-20
 - PANTONE Color sampler chart 5-25
 - RGB color sampler chart 5-25
 - Simulate Display 5-21
 - SWOP Press 5-22
 - Use Printer Setting 5-23
 - Vivid Color (blue) 5-21
 - color density
 - controlling 5-2
 - samples 5-4
 - Color Density Samples*
 - ordering 9-3
 - using 5-4
 - Color Reference Page
 - diagnostic tools 7-5
 - printing 5-2
 - color sampler charts 5-25
 - Commercial Press color correction,
 - description 5-22
 - components
 - installing toner cartridges 2-8
 - ordering 9-2
 - replacing 6-2
 - configuration page 7-4
 - connecting power 2-20
 - connections
 - parallel cables 2-19
 - power 2-20
 - consumables
 - average life 6-3
 - ensuring print quality 6-3
 - ordering 9-2
 - Consumables Page
 - printing 8-8
 - troubleshooting 7-6
 - controlling color density 5-2
 - diagnosing 7-9
 - instructions 5-2
 - Copystation, SCSI ID 2-19
 - correcting printed colors 5-17
 - Custom Install option, software 3-16
- D**
- declaration of conformity 10-2
 - demonstration page 2-23
 - printing 8-8
 - desktop printers, QuickDraw GX
 - printing from 4-17
 - diagnosing print quality 7-4
 - display colors, simulating 5-21
 - DOS, printing from 4-1
 - double-sided printing 4-54
 - drivers, using
 - Adobe PostScript driver
 - Windows 3.1 4-10
 - Windows 95 4-4
 - PostScript driver for Windows NT 3.5 4-8
 - PostScript driver for Windows NT 4.0 4-6
 - Tektronix driver for Windows 3.1 4-9
 - duplex printing
 - using the Multi-Purpose Feeder 4-56
 - using the paper tray 4-54
- E**
- Easy Install option, software 3-16
 - enabling and disabling the startup page 8-10
 - Energy Star
 - front panel menu map 8-7
 - resetting the timeout 2-24
 - envelopes
 - loading Multi-Purpose Feeder 4-48
 - error handler, PostScript 7-27
 - error indicator
 - at power-up 2-21
 - troubleshooting 7-7
 - error messages on the startup page 7-37

- errors, PostScript 7-26
- Ethernet
 - ordering 9-5
 - PhaserShare card and protocols 2-18
 - problems, troubleshooting 7-16
- EuroHAL, automated fax system 7-3
- Euroscale Press color correction,
 - description 5-22
- Extended Features
 - fonts 4-27
 - PCL5 4-28
 - upgrade, ordering 9-6
- external hard disk
 - ordering 9-10
 - SCSI ID 2-19

F

- fabric transfer media
 - loading 4-52
 - ordering 9-2
- Fast Color print mode 4-23
- Fast Monochrome print mode 4-23
- fastest printing available 7-23
- features
 - descriptions 4-20
 - front panel selections 4-21
 - selecting in a Macintosh driver 4-13
 - selecting in a Windows driver 4-2
- fonts
 - descriptions 4-28
 - downloadable (TrueType) 1-3
 - downloading 4-28
 - Extended Features 4-27
 - Macintosh screen fonts 4-28
 - overview 1-3
 - standard configuration 4-26
 - with Extended Features 4-27
 - with Standard configuration 4-26

- front panel
 - buttons 8-2
 - Calibrate Colors** menu, using 5-7
 - Check Print, using 5-11
 - Consumables Page 7-4
 - demonstration page 2-23
 - description 8-1
 - display 8-4
 - Help Pages, using 7-6
 - indicators 8-1
 - locked 8-6
 - menu map 8-7
 - messages, diagnosing problems 7-8
 - messages, troubleshooting 7-7, 7-10
 - printing Help Pages 8-8
 - protected mode 8-6
 - quick reference table 4-21
 - selecting a language 2-22
 - timeout 7-7
 - troubleshooting 7-7
- front panel messages
 - diagnosing problems 7-8
 - locating a media jam 7-39
 - media jams 7-7
 - replace imaging unit 7-10
 - replace toners 7-8
 - waiting for media 7-8
- fuser
 - ordering 9-2
 - replacing 6-7
 - troubleshooting 7-13
- fuser roll
 - average life 6-3
 - diagnosing print quality symptoms 7-13
 - ordering 9-2
 - replacing 6-8

G

- general-purpose printing 5-20
- getting help
 - online services 7-2
 - phone numbers 7-1
- getting the best results 7-30
- glossy paper
 - loading Multi-Purpose Feeder 4-46
 - ordering 9-2

H

- HAL, automated fax system 7-3
 - telephone number and instructions 7-3
- halftone screens 7-30
- hard disk
 - turning on the power 2-20
- hard disk, SCSI ID 2-19
- Help Pages
 - Consumables Page 7-4
 - menu map 8-7
 - printing 8-8
 - service prints 8-8
 - startup page 2-21
- HP-GL, using 4-29
- HSB color sampler chart, printing 5-25
- HSB utility file 5-26

I

- idle mode, front panel 8-2
- image area 4-31
 - size and position 7-18
- image shifts 7-18
- Image Smoothing 5-14
- imaging unit
 - average life 6-3
 - installing 2-12
 - ordering 9-2
 - replacing 6-6
 - troubleshooting 7-10

- improving print speed 7-22
- indicators
 - at power-up 2-21
 - blinking 7-7
 - descriptions 8-1
 - error, troubleshooting 7-7
 - power 7-17
- information access
 - PhaserLink 1-3
- initial setup
 - installing printer software 3-1
 - installing toner cartridges 2-8
 - loading media 2-12
- installation
 - imaging unit 2-12
 - inventory 2-2
 - Lower Tray Assembly 2-7
 - printer software 3-1
 - printer software, Macintosh 3-18
 - printer software, Windows 3-1
 - tasks 2-1
 - toner cartridges 2-8
 - unpacking 2-2
- installing toner cartridges 2-8
- IntelliSelect™ (automatic language selection) 4-29
- interactive mode, front panel 8-2
- inventory 2-2

J

- job collating 5-8

L

- labels, loading 4-50
- language
 - front panel selection 2-22
- laser paper
 - avoiding media jams 7-18
 - general information 4-32

- loading 2-12
- media thickness switch 4-41
- trays 4-34
- weights 4-41
- Legal-size media
 - dimensions 4-30
 - print area 4-31
- Legal-size media tray
 - description 4-34
 - ordering 9-3
- letterhead media
 - loading the Multi-Purpose Feeder 4-45
 - loading the tray 4-37
- Letter-size media trays
 - ordering 9-3
- loading media 2-12
 - duplex printing 4-54
 - initial setup 2-12
 - Multi-Purpose Feeder 4-44
 - trays 2-15
- loading the paper tray, capacity 4-36
- loading the transparency tray, capacity 4-38
- loading transparencies 4-39
- LocalTalk
 - ordering 9-5
 - problems 7-16
- Lower Tray Assembly
 - inserting media trays 2-17
 - installing 2-7
 - ordering 9-3
 - repacking 6-22

M

- Macintosh utility files
 - CMYK Sampler 5-26
 - HSB Sampler 5-26
 - RGB Sampler 5-26
 - Setscreen Patch 7-30

- main charge grid
 - ordering 9-2
 - replacing 6-10
- maintaining print quality
 - cleaning, occasional 6-11
 - replacing consumables 6-1
 - troubleshooting 7-4
- manual feed
 - inserting paper 4-42
 - selecting 4-43
- manuals, ordering 9-3
- margins 4-31
 - incorrect 7-18
- Material Safety Data Sheets (MSDS) 10-4
- media
 - hints and tips 7-38
 - installing 2-12
 - loading letterhead 4-37
 - loading paper tray 4-36
 - loading the transparency tray 4-38
 - loading transparencies 2-15
 - loading trays 2-15
 - Multi-Purpose Feeder 4-44
 - sizes 4-31
 - trays, ordering 9-3
- media hints and tips 4-35
- transparencies 4-39
- troubleshooting 7-38
- media jams
 - avoiding 7-18
 - clearing 7-39
 - Jam at A 7-40
 - Jam at B 7-41
 - Jam at C 7-42
 - Jam at D 7-44
 - Jam at E 7-46
 - Jam at Multi-Purpose 7-46
 - troubleshooting 7-7
- media thickness switch 4-41

- media trays
 - description 4-34
 - loading 2-12
 - ordering 9-3
- memory
 - advantages of upgrading 9-7
 - order numbers 9-7
- menu map 8-7
- Microsoft Windows NT
 - PostScript printer driver, updating 4-8
- moving the printer 6-18
- MSDS, toner 10-5
- multiple copies, collating 5-8
- Multi-Purpose Feeder
 - card stock, loading 4-46
 - double-sided printing 4-56
 - envelopes 4-48
 - fabric transfer 4-52
 - glossy coated paper, loading 4-46
 - labels 4-50
 - letterhead 4-45
 - limit indicator 4-42
 - loading media 2-13
 - setting media thickness 4-41
 - specialty media 4-33
 - using 4-40

N

- network connections
 - ordering 9-8
 - rear panel ports 2-18
- network printing 7-36
- networking, PhaserShare
 - connecting 2-18
 - ordering 9-5
- No Color Correction
 - description 5-20

O

- operating mode, front panel 8-2
- options, ordering 9-9
- ordering
 - cables and adapters 9-4
 - part numbers and descriptions 9-4
- ordering supplies 9-2
- overview of software installation
 - Macintosh 3-16
 - Windows 3.1 3-8
 - Windows 95 3-2
 - Windows NT 3.51 3-6
 - Windows NT 4.0 3-4

P

- packing material
 - removing 2-6
 - repacking 6-23
- PANTONE Colors, printing 5-25
- PANTONE Colors, troubleshooting 7-30
- paper
 - handling 7-38
 - image area 4-31
 - jams, clearing 7-40
 - loading 2-15
 - ordering 9-2
 - picking errors 7-17
- paper limit indicator, Multi-Purpose Feeder 4-42
- paper sizes, description 4-31
- paper tray, loading letterhead 4-37
- paper tray, loading transparencies 4-38
- paper types 1-2
- parallel interface cables
 - connecting 2-19
 - ordering 9-4
- parallel port, connecting 2-19

- PC utility files
 - CMYK.PS 5-26
 - HSB.PS 5-26
 - RGB.PS 5-26
- PC/Windows software 3-1
- PCL5 4-28
 - Extended Features 4-28
 - printer languages 4-29
- peripheral devices 2-19
- Phaser 560 Color Density Samples* 5-4
- Phaser 560 driver
 - setting up 3-19
 - using 4-15
- Phaser 560 GX driver
 - setting up 3-21
 - using 4-17
- Phaser 560 Quick Reference Guide*
 - ordering 9-3
 - using 7-5
- Phaser 560 utilities
 - downloading fonts 4-28
- Phaser Copystation
 - getting set up 2-19
 - ordering 9-9
- PhaserLink software 4-20
 - getting consumables information 7-4
- PhaserPrint software 9-10
 - for workstations, description 4-18
 - for workstations, using 7-25
 - ordering 9-10
 - Photoshop plug-in 3-17
- PhaserShare cards
 - configuring 2-18
 - ordering 9-8
- PhaserShare manuals, ordering 9-3
- phone numbers
 - automated fax systems 7-3
 - customer support, supplies 7-1
 - EuroHAL 7-3
 - HAL, OzHAL 7-2
- ports, printer
 - overview 2-18
 - parallel 2-19
 - PhaserShare 2-18
 - speed 7-22
- PostScript 4-29
 - error handler 7-27
 - errors, general 7-26
 - fonts 4-27
 - printing errors 7-26
- PostScript Header
 - Windows 3.1 driver 4-10
 - Windows 95 driver 4-5
- power indicator 7-17
 - at power-up 2-21
 - blinking 7-7
- power, connecting 2-20
- power-up 2-21
- pre-cut labels, loading 4-50
- Presentation print mode 4-23
- previewing a job 5-11
- print a truer blue 5-21
- print area 4-31
- print features
 - automatic tray switching 5-14
 - collating multiple copies 5-8
 - color corrections 4-24
 - color density 5-2
 - front panel selections 4-21
 - Image Smoothing 5-14
 - output order 4-25
 - previewing 5-11
 - print-quality modes 4-23
 - selecting 4-20
- print quality
 - cleaning, occasional 6-11
 - maintaining 7-4
 - problems 7-19
 - replacing consumables 6-1
 - selections 4-20

- print quality quick reference table 7-7
- print speed
 - hints 7-23
 - improving 7-22
- printer configuration information 7-35
- printer control
 - PhaserLink 1-3
 - selecting features 4-20
- printer drivers, using
 - Adobe PostScript driver
 - Windows 3.1 4-10
 - Windows 95 4-4
 - AdobePS 3 (Windows 3.1) 4-10
 - PostScript driver for Windows NT 3.5 4-8
 - PostScript driver for Windows NT 4.0 4-6
 - Tektronix driver for Windows 3.1 4-9
- printer languages 4-29
- printer weight
 - installing 2-7
 - repacking 6-22
 - specifications 10-8
- PRINTER.INF*, updating Windows NT driver 4-8
- printing
 - from a Macintosh 4-12
 - from a PC 4-1
 - Help Pages 8-8
 - on a network 4-24
 - time 7-23
 - timeout 7-17
- Printing menu, QuickDraw GX printer driver
 - Start Print Queue command 4-17
 - Stop Print Queue command 4-17
- printing mode, front panel 8-2
- printing on a network 7-36
- printing PANTONE Colors 7-30
- printing press color corrections 5-22
- printing, from applications 4-20
- print-quality modes 4-23
 - standard configuration 4-23

- problems and solutions, diagnostic tools 7-4
- protected mode, front panel 8-6
- PS Error Handler 7-5

Q

- Quick Collate option
 - increasing capacity 5-10
 - using with the Check Print option 5-10
- Quick Collate option 5-8
- quick reference
 - selecting features, front panel 4-21
 - selecting features, Macintosh 4-13
 - selecting features, Windows 4-2
- quick reference guide, ordering 9-3
- quick reference table, troubleshooting 7-7
- QuickDraw GX driver
 - Printing menu
 - Start Print Queue** command 4-17
 - Stop Print Queue** command 4-17
- QuickDraw GX driver, printing from
 - GX-aware applications 4-17
 - non-GX aware applications 4-17

R

- registering your printer 2-5
- registration page 2-21
- regulatory information 10-1
- repacking 6-18
 - Lower Tray Assembly 6-22
 - shipping box 6-23
- replaceable components
 - average life 6-3
 - ordering 9-2
- replacing consumables
 - overview 6-1
- resident fonts 4-27
- resident typefaces (PCL5) 4-28
- RGB color sampler chart 5-25
- RGB utility file 5-26

S

- SCSI
 - devices, connecting 2-19
 - devices, ordering 9-10
 - ID numbers 2-19
- selecting page sizes in Windows applications 7-33
- self-tests 2-21
- service print 7-6
- Setscreen 7-30
- setting up the printer 2-2
- simple color conversions, CMYK and RGB 5-23
- Simulate Display color correction
 - description 5-21
- software, drivers
 - installation 3-1
 - setup on a network, Windows NT 3.5 3-12
- solutions, problem solving 7-4
- specialty media 1-2
 - loading 4-44
- specifications 10-7
- standard configuration
 - fonts 4-26
 - print-quality modes 4-23
- Standard print mode 4-23
- startup page 2-21
 - enabling and disabling 8-10
 - error messages 7-37
 - prints at power-up 2-21
 - prints when disabled 7-37
 - reports error message 7-37
 - troubleshooting information 7-37
- streaks or spots on prints 7-20
- supplies and accessories
 - ordering 9-2
 - printing hints 7-21
- SWOP Press color correction, description 5-22

- symptoms and solutions 7-4
 - adjusting color density 5-2
 - color calibration page 5-2
 - Consumables Page 7-4
 - Phaser 560 Quick Reference Guide* 7-5

T

- TekColor Dynamic Correction 4-24
- Tektronix Bulletin Board Service (BBS) 3-22
- Tektronix driver for Windows 3.1
 - using 4-9
- test print button, troubleshooting 7-16
- test print, Consumables Page 7-4
- timeouts 7-17
 - Windows 95 driver 4-10
- Token Ring
 - ordering 9-8
 - PhaserShare card and protocols 2-18
- toner cartridges
 - average life 6-3
 - installing 2-8
 - ordering 9-2
 - replacing 6-5
 - shipping cover 2-8
- toner MSDS 10-5
- transfer kit
 - average life 6-3
 - replacing 6-9
- Transmission Retry
 - Windows 4-10
- transparencies
 - jams, clearing 7-40
 - loading the Multi-Purpose Feeder 4-44
 - loading the tray 4-38
 - ordering 9-2
 - picking errors 7-17
- transparency tray
 - loading 2-15
 - ordering 9-3

- troubleshooting
 - black and white prints instead of color 7-20
 - bleeding colors 7-11
 - clearing media jams 7-39
 - cut off images 7-18
 - dark, vertical line 7-12
 - fine-line detail missing 7-10
 - fingerprints 7-12
 - frequent paper-picking errors 7-17
 - image shifts (Macintosh) 7-18
 - image size and position 7-18
 - light spots 7-12
 - light vertical line 7-10
 - margins incorrect (Macintosh) 7-18
 - media jams 7-18
 - off-set images 7-18
 - paper-picking errors 7-17
 - power light blinks, but file doesn't print 7-17
 - print job does not finish 7-17
 - print quality problems 7-19
 - printer doesn't appear in the Chooser 7-16
 - Printer Error ## 7-15
 - print-quality 7-19
 - repeating light spot 7-9
 - startup page prints when disabled 7-37
 - streaks or spots 7-20
 - TrueType fonts 1-3, 4-28
 - turning on the printer 2-20
 - typefaces, resident 1-3
- U**
- UNIX workstations 4-19
 - installing printer software 3-22
 - unpacking 2-2
 - upgrade kits 9-5
 - Ethernet 9-5
 - LocalTalk support 9-5
 - serial support 9-5
 - Use Printer Setting color correction description 5-23
 - user-replaceable components 6-2
 - fuser 6-7
 - fuser roll 6-8
 - imaging unit 6-6
 - main charge grid 6-10
 - ordering 9-2
 - toner cartridges 6-5
 - transfer kit 6-9
 - using color 5-16, 5-18
 - using Windows 3.1 drivers
 - Adobe PostScript 4-10
 - Tektronix driver 4-9
 - using Windows 95 drivers
 - AdobePS 4 4-4
 - using Windows NT 3.5 PostScript drivers 4-8
 - using Windows NT PostScript drivers 4-6
 - utility files, downloading 3-22

V

Vivid Color color correction
description 5-21

W

Windows 3.1 driver

PostScript Header 4-10

PostScript tab 4-10

problems with printer fonts 7-35

problems with setting page sizes 7-33

timeout problems 7-28

using the Adobe PostScript driver 4-10

using the Tektronix driver 4-9

Windows 95 driver

Device Options tab 4-4

Graphics tab 4-4

Paper tab 4-10

PostScript Header 4-5

PostScript tab 4-5

problems with printer fonts 7-35

timeout problems 7-28

timeouts, setting 4-10

using 4-10

Windows NT 3.5 and 3.51

setting up on a network 3-12

Windows NT 4.0

setting up on a network 3-14

Windows NT PostScript printer driver,

updating 4-8

workstation software

PhaserPrint for UNIX software 9-10